

SIEMENS

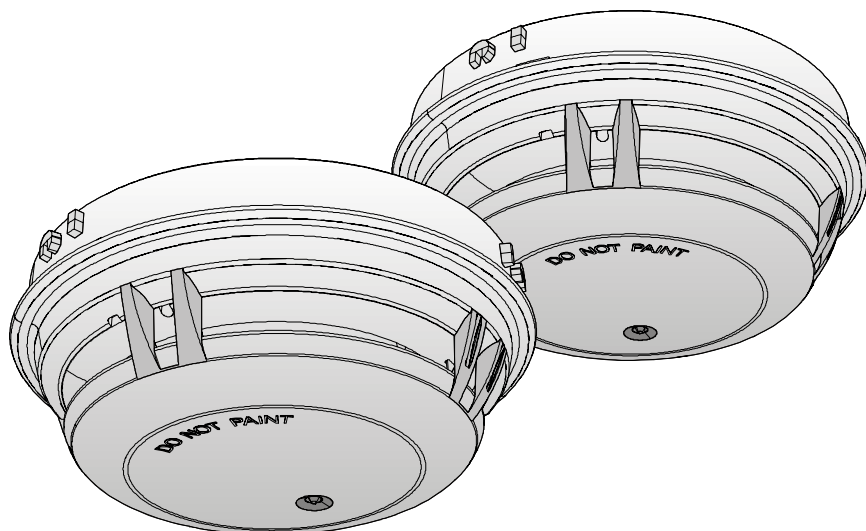

OOH740, OOHC740

Automatic fire detectors

Technical Manual

Legal notice

Technical specifications and availability subject to change without notice.

Transmittal, reproduction, dissemination and/or editing of this document as well as utilization of its contents and communication thereof to others without express authorization are prohibited. Offenders will be held liable for payment of damages. All rights created by patent grant or registration of a utility model or design patent are reserved.

Issued by:
Siemens Switzerland Ltd.
Building Technologies Division
International Headquarters
Gubelstrasse 22
CH-6301 Zug
Tel. +41 41 724-2424
www.siemens.com/buildingtechnologies

Edition: 2016-03-23
Document ID: A6V10305793_n_en_--

© Siemens Switzerland Ltd, 2010

Table of contents

1	About this document	7
1.1	Applicable documents.....	9
1.2	Download center.....	10
1.3	Technical terms.....	10
1.4	History of changes.....	11
2	Safety	14
2.1	Safety instructions.....	14
2.2	Safety regulations for the method of operation.....	16
2.3	Standards and directives complied with.....	18
2.4	Release Notes.....	18
3	Structure and function	19
3.1	Overview.....	19
3.1.1	Multi-sensor smoke detector, ASA OOH740.....	20
3.1.2	Neural fire detector OOHC740.....	21
3.1.3	Features of fire detection functionality.....	22
3.1.4	Features of the 'Technical CO Alarm'.....	24
3.1.5	Features of the 'Technical Ambient Supervision Message'.....	26
3.1.6	Details for ordering.....	26
3.1.7	Product version ES.....	27
3.2	Setup.....	28
3.2.1	Structure of OOH740.....	28
3.2.2	Structure of OOHC740.....	29
3.3	Function.....	32
3.3.1	Parameter sets.....	32
3.3.1.1	Parameter sets for fire detection.....	33
3.3.1.2	Parameter sets for 'Technical CO Alarm'.....	36
3.3.2	Danger levels and warning levels.....	37
3.3.2.1	Danger levels for fire detection.....	37
3.3.2.2	Warning levels for CO.....	38
3.3.2.3	Danger levels for 'Technical Ambient Supervision Message'.....	38
3.3.3	Diagnosis levels.....	39
3.3.4	Line separator.....	39
3.3.5	Internal alarm indicator in the case of ES <20 (OOH740 and OOHC740).....	40
3.3.6	External alarm indicator in the case of ES <20 (OOH740 and OOHC740).....	41
3.3.7	Advanced flashing behavior of the alarm indicators in the case of ES ≥20 (OOH740 and OOHC740).....	41
3.3.8	Connection for external alarm indicators.....	43
3.3.9	Renovation mode.....	43
3.3.10	Test mode.....	44

3.3.11	Behavior in degraded mode	45
3.3.12	Line tester.....	45
3.4	Mechanical setup.....	46
3.5	Accessories	47
3.5.1	Detector base with loop contact DB721.....	47
3.5.2	Detector base DB722.....	48
3.5.3	Detector base DB721D	49
3.5.4	Detector base (collective) DB110	49
3.5.5	Sounder base DBS720	50
3.5.6	Designation plate FDBZ291	50
3.5.7	Detector base seal RS720	50
3.5.8	Base attachment BA720	51
3.5.9	Base attachment wet BA721	51
3.5.10	Designation plate DBZ1193A	51
3.5.11	Detector heating unit FDBH291.....	52
3.5.12	Protective cage DBZ1194	52
3.5.13	Detector locking device LP720	52
3.5.14	Micro terminal DBZ1190-AA.....	53
3.5.15	Connection terminal DBZ1190-AB.....	53
3.5.16	Parameter set resistor 33 kΩ PSR720-1.....	53
3.5.17	Parameter set resistance 68 kΩ PSR720-2	54
4	Planning	55
4.1	Compatibility.....	55
4.2	Fire detection.....	55
4.2.1	Ambient features.....	55
4.2.2	Parameter sets: Sensor mode 0 'Neural fire detector'	56
4.2.2.1	Description	56
4.2.2.2	Use	58
4.2.2.3	Specification	59
4.2.3	Parameter sets: Sensor mode 1 'Heat detector'.....	60
4.2.4	Parameter sets: Sensor mode 2 'Smoke detector'	60
4.2.4.1	Description.....	60
4.2.4.2	Use	61
4.2.4.3	Specification	61
4.2.5	Parameter sets for collective operation.....	62
4.2.5.1	Description.....	62
4.2.5.2	Use	62
4.2.5.3	Specification	63
4.2.6	Default settings for operating on the C-NET	63
4.2.7	Setting the parameter set in collective operation.....	64
4.2.8	Sample applications for OOH740	64
4.2.9	Sample applications for OOH740.....	65

4.3	Technical CO alarm.....	66
4.3.1	Parameter sets for the 'Technical CO Alarm'.....	66
4.3.1.1	Description.....	66
4.3.1.2	Use.....	67
4.3.1.3	Specification.....	68
4.3.1.4	Default settings.....	68
4.3.1.5	Application examples.....	69
4.3.2	Ambient features.....	69
4.4	Technical Ambient Supervision Message.....	70
4.4.1	Ambient features.....	70
4.4.1.1	Temperature monitoring.....	72
4.4.1.2	CO monitoring.....	72
4.4.2	Configuration.....	73
4.4.3	Default settings.....	73
5	Mounting / Installation.....	74
5.1	Required space.....	74
5.2	Detector base DB72x and detector base (collective) DB110.....	75
5.3	Sounder base DBS720.....	77
5.4	Detector base seal RS720.....	78
5.5	Base attachment BA720.....	79
5.6	Base attachment wet BA721.....	80
5.7	Detector locking device LP720.....	83
5.8	Designation plate FDBZ291.....	84
5.9	Cable entry.....	85
5.9.1	Auxiliary terminals DBZ1190-AA/-AB.....	86
5.10	Detector lines.....	86
5.10.1	Connection diagram, addressed.....	86
5.10.2	Connection diagram, collective.....	88
5.11	Detector dust cap.....	90
5.12	Detector heating unit FDBH291.....	91
5.12.1	Installation of the detector heating unit.....	91
5.12.2	Connection of the detector heating unit.....	92
5.13	Migration from collective detector line to addressed detector line.....	93
5.13.1	Removing the diode unit.....	94
6	Commissioning.....	95
6.1	Commissioning on the C-NET.....	95
6.2	Commissioning on a collective detector line.....	95

7	Maintenance / Repair	96
7.1	Performance check.....	96
7.2	Testing the point detector	96
7.2.1	Test mode on the control panel	97
7.2.2	Testing the fire detection functionality.....	98
7.2.3	Testing the CO functionality (only for OOH740)	98
7.2.4	Testing the functionality of the 'Technical Ambient Supervision Message'	99
7.2.4.1	'Technical Ambient Supervision Message' performance check.....	99
8	Specifications	100
8.1	Technical data for OOH740	100
8.2	Technical data for OOH740.....	103
8.3	Dimensions	105
8.4	Environmental compatibility	106
	Index	107

1 About this document

Goal and purpose

This document contains all the information you'll need on automatic fire detectors

- OOH740
- OOHC740

Following the instructions consistently will ensure that the product can be used safely and without any problems.

Intended use

The automatic fire detectors OOH740 and OOHC740 may only be used on a C-NET detector line in a FS720 fire detection system.

The automatic fire detector OOH740 may also be used on a collective detector line or a conventional detector line.

Target groups

The information in this document is intended for the following target groups:

Target group	Activity	Qualification
Product Manager	<ul style="list-style-type: none"> • Is responsible for information passing between the manufacturer and regional company. • Coordinates the flow of information between the individual groups of people involved in a project. 	<ul style="list-style-type: none"> • Has obtained suitable specialist training for the function and for the products. • Has attended the training courses for Product Managers.
Project Manager	<ul style="list-style-type: none"> • Coordinates the deployment of all persons and resources involved in the project according to schedule. • Provides the information required to run the project. 	<ul style="list-style-type: none"> • Has obtained suitable specialist training for the function and for the products. • Has attended the training courses for Project Managers.
Project engineer	<ul style="list-style-type: none"> • Sets parameters for product depending on specific national and/or customer requirements. • Checks operability and approves the product for commissioning at the place of installation. • Is responsible for troubleshooting. 	<ul style="list-style-type: none"> • Has obtained suitable specialist training for the function and for the products. • Has attended the training courses for Product Engineer.
Installation personnel	<ul style="list-style-type: none"> • Assembles and installs the product components at the place of installation. • Carries out a performance check following installation. 	<ul style="list-style-type: none"> • Has received specialist training in the area of building installation technology or electrical installations.
Maintenance personnel	<ul style="list-style-type: none"> • Carries out all maintenance work. • Checks that the products are in perfect working order. • Searches for and corrects malfunctions. 	<ul style="list-style-type: none"> • Has obtained suitable specialist training for the function and for the products.

Source language and reference document

- The source/original language of this document is German (de).
- The reference version of this document is the international version in English. The international version is not localized.

Document identification

The document ID is structured as follows:

ID code	Examples
ID_ModificationIndex_Language_COUN TRY -- = multilingual or international	A6V10215123_a_de_DE A6V10215123_a_en_-- A6V10315123_a_--_--

Date format

The date format in the document corresponds to the recommendation of international standard ISO 8601 (format YYYY-MM-DD).

Conventions for text marking

Markups

Special markups are shown in this document as follows:

>	Requirement for a behavior instruction
1. 2.	Behavior instruction with at least two operation sequences
–	Version, option, or detailed information for a behavior instruction
⇒	Intermediate result of a behavior instruction
⇨	End result of a behavior instruction
•	Numbered lists and behavior instructions with an operation sequence
[→ X]	Reference to a page number
'Text'	Quotation, reproduced identically
<Key>	Identification of keys
>	Relation sign and for identification between steps in a sequence, e.g., 'Menu bar' > 'Help' > 'Help topics'
↑ Text	Identification of a glossary entry

Supplementary information and tips



The 'i' symbol identifies supplementary information and tips for an easier way of working.

1.1 Applicable documents

Document ID	Name
008250	Technical Manual Line tester FDUL221
009122	Technical manual Input/output module (transponder) FDCIO223
A6V10200373	Installation Detector base with loop contact DB721, DB722, detector base DB720, sounder base DBS720, detector base seal RS720, detector locking device LP720, base attachment BA720
A6V10201731	Installation Detector exchanger DX791, adapter for detector exchanger FDUD491
A6V10210416	FS720 Fire detection system - Commissioning, Maintenance, Troubleshooting
A6V10210424	FS720 Fire detection system - Configuration
A6V10229261	List of compatibility (for 'Cerberus™ PRO' product line)
A6V10254740	Operating instructions Solo461 heat detector tester kit RE7T
A6V10284161	Data sheet Automatic fire detectors OOH740, OOH740
A6V10316300	Installation Detector base (collective) DB110, DB110D, DB110R, DB110RD, detector base seal RS720, detector locking device LP720, base attachment BA720
A6V10323905	Installation Detector base DB721D, detector base seal RS720, detector locking device LP720
A6V10406006	Installation Base attachment wet BA721, Detector designation plate DBZ1193A, Protective cage DBZ1194, EMC-protective cage FDBZ294

Please also observe the documentation for your fire detection system.

1.2 Download center

You can download various types of documents, such as data sheets, installation instructions, and license texts via the following Internet address:

<http://siemens.com/bt/download>

- Enter the document ID in the 'Find by keyword' input box.



You will also find information about search variants and links to mobile applications (apps) for various systems on the home page.

1.3 Technical terms

Term	Explanation
AI	Alarm indicator
ASA (<i>ASAtechnology™</i>)	Advanced Signal Analysis
CO	Carbon monoxide
EAI	External alarm indicator
EOL	End-of-line
ES	Product version
C-NET	Addressed detector line
IAI	Internal alarm indicator
LED	Light-emitting diode
MAK value	Maximum concentration at the workplace: maximum permissible concentration of a toxic substance in the air at the workplace

1.4 History of changes

The reference document's version applies to all languages into which the reference document is translated.



The first edition of a language version or a country variant may, for example, be version 'd' instead of 'a' if the reference document is already this version.

The table below shows this document's revision history:

Modification index	Edition date	Brief description
n	2016-03-23	<ul style="list-style-type: none"> • Corrections in the 'Line separator' chapter
m	2016-02-15	<ul style="list-style-type: none"> • Intended use added • Extended flashing behavior of the alarm indicators added • Additions to the 'Detector base DB72x and detector base (collective) DB110' chapter • EMC-protective cage FDBZ294 removed as accessory part • Temperature ranges for 'Technical Ambient Supervision Message' corrected • Editorial changes • Changes in the following chapters: <ul style="list-style-type: none"> – 'Multi-sensor smoke detector, ASA OOH740' – 'Neural fire detector OOH740' – 'Structure of OOH740' – 'Parameter sets for fire detection' – 'Behavior in degraded mode operation' – 'Line separator' – 'External alarm indicator in the case of ES <20 (OOH740 and OOH740)' – 'Extended flashing behavior of the alarm indicators in the case of ES ≥20 (OOH740 and OOH740)' – 'Detector base DB722' – 'Compatibility' – 'Fire detection' > 'Specification' – 'Parameter sets: Sensor mode 0 'Neural fire detector' ' > 'Description' – 'Parameter sets: Sensor mode 0 'Neural fire detector' ' > 'Application' – 'Parameter sets: Sensor mode 2 'Smoke detector' > 'Description' – 'Parameter sets: Sensor mode 2 'Smoke detector' > 'Application' – 'Parameter sets for collective operation' > 'Specification' – 'Default settings for operating on the C-NET' – 'Sample applications for OOH740' – 'Sample applications for OOH740'

Modification index	Edition date	Brief description
m	2016-02-15	<ul style="list-style-type: none"> – 'Parameter sets for the 'Technical CO Alarm' ' > 'Description' – 'Parameter sets for the 'Technical CO Alarm' ' > 'Specification' – 'Parameter sets for the 'Technical CO Alarm' ' > 'Sample applications' – 'Technical 'Ambient Supervision' Message' > 'Ambient features' – 'Detector base DB72x and detector base (collective) DB110' – 'Base attachment BA720' – 'Connection diagram, addressed' – 'Connection diagram, collective' – 'Migration from collective detector line to addressed detector line' – 'Testing the fire detection functionality' – 'Testing the CO functionality' – ' 'Technical Ambient Supervision Message' function check' – 'Technical data' • 'Danger levels for 'Technical Ambient Supervision Message' ' chapter corrected
l	2014-05-08	Data sheet in 'Applicable documents' chapter added; new parameter sets added; 'Technical Ambient Supervision Message' made available in point detector OOH740; various changes in the 'Specifications' chapter; editorial changes; base attachment wet BA721, designation plate DBZ1193A, protective cage DBZ1194, EMC-protective cage FDBZ294, and detector heating unit FDBH291 added, 'Download center' chapter added; addition parameter sets for OOH740 added; changes made to 'Compatibility' chapter
k	2013-04-04	Technical data adapted
j	2013-01-25	LPCB approvals added
i	2012-08-16	Details concerning product version corrected in 'Planning' chapter; notice added: Parameter sets 'Balanced CO' and 'Suppression CO' do not have LPCB approval; date format changed in accordance with specifications of ISO 8601 (format: yyyy-mm-dd)
h	02.2012	Detector base DB722 and base attachment BA720 added, marine approval for OOH740 added
g	11.2011	OOH740: VdS approval and CPD number added
f	09.2011	IP protection categories adapted
e	06.2011	Chapter 'Removing the diode unit' added
d	05.2011	Detector base DB110 added

Modification index	Edition date	Brief description
c	02.2011	Removing the diode unit on the detector base DB721D changed; detector designations changed
b	12.2010	Editorial revision; detector base DB721D added
a	07.2010	First edition



The language versions and country variants produced by a local company have the same modification index as the corresponding reference document. They are not however included in the table below.

The table below shows the published language versions with the corresponding modification index:

Modification index	en_--	de_--	fr_--	it_--	es_--
n	X	X	X	X	X
m	X	X	X	X	X
l	X	X	X	X	X
k	X	X	X	X	X
j	X	X	X	X	X
i	X	X	X	X	X
h	X	X	X	X	X
g	X	X	X	X	X
f	X	X	X	X	X
e	X	X	X	X	X
d	X	X	X	X	X
c	–	X	–	–	–
b	X	X	–	–	–
a	–	X	–	–	–

X = published

– = no publication with this modification index

2 Safety

2.1 Safety instructions

The safety notices must be observed in order to protect people and property.

The safety notices in this document contain the following elements:

- Symbol for danger
- Signal word
- Nature and origin of the danger
- Consequences if the danger occurs
- Measures or prohibitions for danger avoidance

Symbol for danger



This is the symbol for danger. It warns of **risks of injury**.
Follow all measures identified by this symbol to avoid injury or death.

Additional danger symbols

These symbols indicate general dangers, the type of danger or possible consequences, measures and prohibitions, examples of which are shown in the following table:



General danger



Explosive atmosphere



Voltage/electric shock



Laser light



Battery



Heat

Signal word

The signal word classifies the danger as defined in the following table:

Signal word	Danger level
DANGER	DANGER identifies a dangerous situation, which will result directly in death or serious injury if you do not avoid this situation.
WARNING	WARNING identifies a dangerous situation, which may result in death or serious injury if you do not avoid this situation.
CAUTION	CAUTION identifies a dangerous situation, which could result in slight to moderately serious injury if you do not avoid this situation.
<i>NOTICE</i>	<i>NOTICE</i> identifies possible damage to property that may result from non-observance.

How risk of injury is presented

Information about the risk of injury is shown as follows:

	<p>⚠ WARNING</p>
	<p>Nature and origin of the danger Consequences if the danger occurs</p> <ul style="list-style-type: none"> • Measures / prohibitions for danger avoidance

How possible damage to property is presented

Information about possible damage to property is shown as follows:



	<p><i>NOTICE</i></p>
	<p>Nature and origin of the danger Consequences if the danger occurs</p> <ul style="list-style-type: none"> • Measures / prohibitions for danger avoidance

2.2 Safety regulations for the method of operation

National standards, regulations and legislation

Siemens products are developed and produced in compliance with the relevant European and international safety standards. Should additional national or local safety standards or legislation concerning the planning, mounting, installation, operation or disposal of the product apply at the place of operation, then these must also be taken into account together with the safety regulations in the product documentation.

Electrical installations

	<p>⚠ WARNING</p>
	<p>Electrical voltage Electric shock</p> <ul style="list-style-type: none"> • Work on electrical installations may only be carried out by qualified electricians or by instructed persons working under the guidance and supervision of a qualified electrician, in accordance with the electrotechnical regulations.
<ul style="list-style-type: none"> • Wherever possible disconnect products from the power supply when carrying out commissioning, maintenance or repair work on them. • Lock volt-free areas to prevent them being switched back on again by mistake. • Label the connection terminals with external external voltage using a 'DANGER External voltage' sign. • Route mains connections to products separately and fuse them with their own, clearly marked fuse. • Fit an easily accessible disconnecting device in accordance with IEC 60950-1 outside the installation. • Produce earthing as stated in local safety regulations. 	
	<p>⚠ CAUTION</p>
	<p>Noncompliance with the following safety regulations Risk of injury to persons and damage to property</p> <ul style="list-style-type: none"> • Compliance with the following regulations is required.
	<ul style="list-style-type: none"> • Specialist electrical engineering knowledge is required for installation. • Only an expert is permitted to carry out installation work. <p>Incorrect installation can take safety devices out of operation unbeknown to a layperson.</p>

Mounting, installation, commissioning and maintenance

- If you require tools such as a ladder, these must be safe and must be intended for the work in hand.
- When starting the fire control panel ensure that unstable conditions cannot arise.
- Ensure that all points listed in the 'Testing the product operability' section below are observed.
- You may only set controls to normal function when the product operability has been completely tested and the system has been handed over to the customer.

Testing the product operability

- Prevent the remote transmission from triggering erroneously.
- If testing building installations or activating devices from third-party companies, you must collaborate with the people appointed.
- The activation of fire control installations for test purposes must not cause injury to anyone or damage to the building installations. The following instructions must be observed:
 - Use the correct potential for activation; this is generally the potential of the building installation.
 - Only check controls up to the interface (relay with blocking option).
 - Make sure that only the controls to be tested are activated.
- Inform people before testing the alarm devices and allow for possible panic responses.
- Inform people about any noise or mist which may be produced.
- Before testing the remote transmission, inform the corresponding alarm and fault signal receiving stations.

Modifications to the system design and the products

Modifications to the system and to individual products may lead to faults, malfunctioning and safety risks. Written confirmation must be obtained from Siemens and the corresponding safety bodies for modifications or additions.

Modules and spare parts

- Components and spare parts must comply with the technical specifications defined by Siemens. Only use products specified or recommended by Siemens.
- Only use fuses with the specified fuse characteristics.
- Wrong battery types and improper battery changing lead to a risk of explosion. Only use the same battery type or an equivalent battery type recommended by Siemens.
- Batteries must be disposed of in an environmentally friendly manner. Observe national guidelines and regulations.

Disregard of the safety regulations

Before they are delivered, Siemens products are tested to ensure they function correctly when used properly. Siemens disclaims all liability for damage or injuries caused by the incorrect application of the instructions or the disregard of danger warnings contained in the documentation. This applies in particular to the following damage:

- Personal injuries or damage to property caused by improper use and incorrect application
- Personal injuries or damage to property caused by disregarding safety instructions in the documentation or on the product
- Personal injury or damage to property caused by poor maintenance or lack of maintenance

2.3 Standards and directives complied with

A list of the standards and directives complied with is available from your Siemens contact.

2.4 Release Notes

Limitations to the configuration or use of devices in a fire detection installation with a particular firmware version are possible.

	⚠ WARNING
	<p>Limited or non-existent fire detection Personal injury and damage to property in the event of a fire.</p> <ul style="list-style-type: none"> • Read the 'Release Notes' before you plan and/or configure a fire detection installation. • Read the 'Release Notes' before you carry out a firmware update to a fire detection installation.

	NOTICE
	<p>Incorrect planning and/or configuration Important standards and specifications are not satisfied. Fire detection installation is not accepted for commissioning. Additional expense resulting from necessary new planning and/or configuration.</p> <ul style="list-style-type: none"> • Read the 'Release Notes' before you plan and/or configure a fire detection installation. • Read the 'Release Notes' before you carry out a firmware update to a fire detection installation.

3 Structure and function

3.1 Overview

In this document the following point detectors are referred to collectively using the term 'Automatic fire detectors':

- Multi-sensor smoke detector, ASA OOH740
- Neural fire detector OOHC740

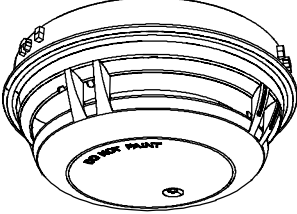
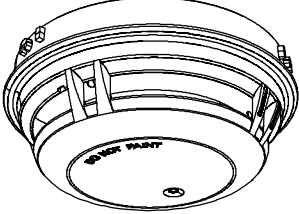
Multi-sensor smoke detector, ASA OOH740	Neural fire detector OOHC740
	
Can be used addressed in the C-NET and in collective mode	Can be used addressed on the C-NET
Detection behavior can be selected	

3.1.1 Multi-sensor smoke detector, ASA OOH740

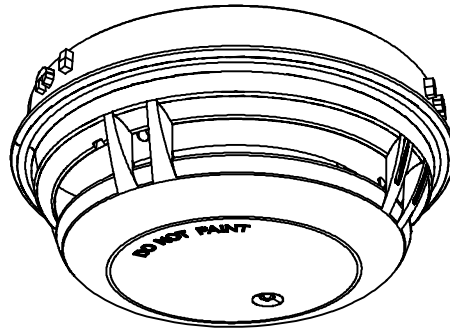

Figure 1: Multi-sensor smoke detector, ASA OOH740

Properties

- Communication via C-NET (addressed detector line)
- Address automatically issued during commissioning
- Can also be used on collective detector lines in conjunction with the detector bases DB721D and DB110
- Built-in line separator
- Signal processing with **ASA technology** and optional detection behavior (application-specific ASA parameter sets)
- Software can be used to set as:
 - Neural fire detector
 - Wide-spectrum smoke detector
 - Heat detector
- Red LED as alarm indicator
- The following functions are also included from point detector product version [→ 27] ES ≥20:
 - 'Technical Ambient Supervision Message' mode can be selected
 - Extended flashing behavior of the internal alarm indicator
 - Additional 'Super Sensitive' and 'Ultra Sensitive' parameter sets



Check the version of your FS720 control panel. Some features are only available as of certain versions. You will find details in the 'List of compatibility'.

3.1.2 Neural fire detector OOHC740

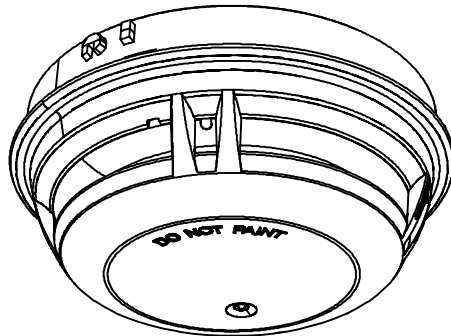

Figure 2: Neural fire detector OOHC740

Properties

- Communication via C-NET (addressed detector line)
- Address automatically issued during commissioning
- Built-in line separator
- Signal processing with **ASA technology** and optional detection behavior (application-specific ASA parameter sets)
- Software can be used to set as:
 - Neural fire detector
 - Neural CO-supported fire detector
 - Wide-spectrum smoke detector
 - Heat detector
- Detection behavior of the 'Technical CO Alarm' can be set regardless of the ASA parameter sets for fire detection. Can be set using software.
- 'Technical CO Alarm': Detection of carbon monoxide (CO) at concentrations of 5 ppm CO or more (MAK value=30 ppm CO)
- 'Technical Ambient Supervision Message': Adjustable hysteresis-induced ambient monitoring of temperature or carbon monoxide. Can be set using software.
- From point detector product version [→ 27] ES ≥20: Extended flashing behavior of the internal alarm indicator
- Red LED as alarm indicator



Check the version of your FS720 control panel. Some features are only available as of certain versions. You will find details in the 'List of compatibility'.

See also

- 📄 Applicable documents [→ 9]

3.1.3 Features of fire detection functionality

Properties

- Dynamic influence on the parameter sets
- Pattern recognition
- Real time interpretation of the situation
- Process- and time-controlled switchover of the parameter sets

Signal processing of the point detectors is based on **ASA technology** (ASA = Advanced Signal Analysis). **ASA technology** can also be characterized as "second generation algorithms". Signal processing with **ASA technology** allows for optimum adaptation of detector behavior to the corresponding ambient conditions.

Point detectors with **ASA technology** are characterized by their unique detection reliability and very high resistance to deceptive phenomena.

Operating mode: Signal processing with **ASA technology**

The figure below shows signal processing on point detectors with **ASA technology** in the form of a diagram:

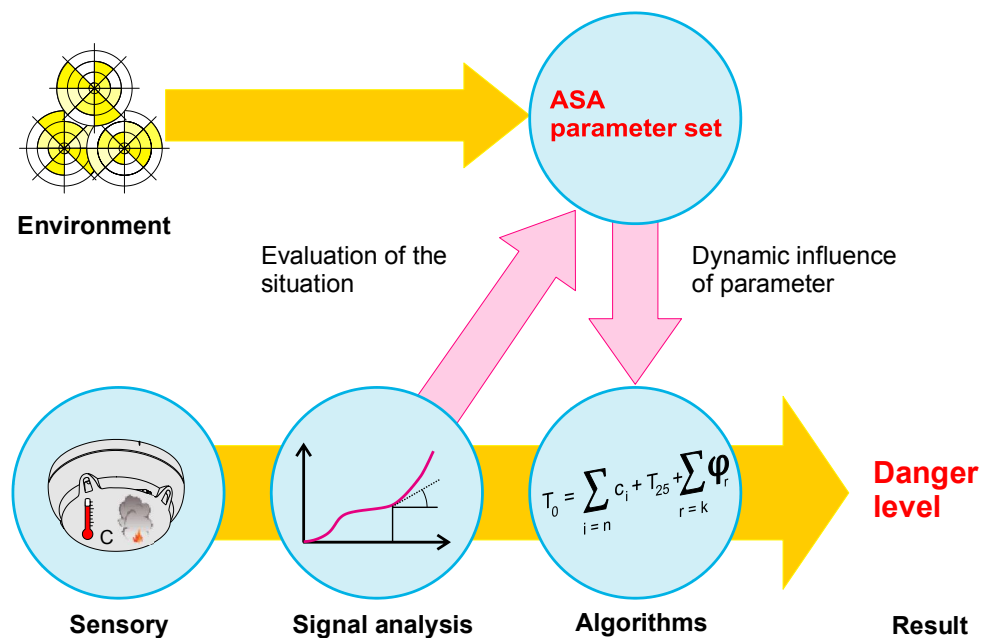

Figure 3: Signal processing with **ASA technology**

Sensory

The signals captured by the sensory are transmitted to the algorithm. The algorithms are set by selecting the parameter set.

Algorithms

The individual parameters in the selected parameter set can be adapted with **ASAt**technology. A real time interpretation of the situation leads to a dynamic influence on the algorithm. This results in the parameter set's and therefore the point detector's application range broadening. The detector reacts more sensitively in the event of fire, and more robustly in the event of deceptive phenomena.

Switching over the parameter set

In addition to selecting the parameter set, the point detectors with **ASAt**technology enable time- or process-controlled switching over of the parameter sets (Manned/Unmanned switchover). Thanks to this function, the detector can be used in places where the situation changes regularly and frequently (e.g. kitchens, production halls).

Downloadable parameter sets

Point detectors with **ASAt**technology have several permanently programmed parameter sets. For special applications new, additional parameter sets can be downloaded in the field (depending on the control panel).

3.1.4 Features of the 'Technical CO Alarm'



The 'Technical CO Alarm' mode can only be selected on the point detector OOHC740.

Alongside its fire detection functionality, the point detector also has a CO detection functionality with the following features:

- Static or dynamic alarm profiles
- Real time interpretation of the situation
- Process- and time-controlled switchover of the parameter sets for CO

Signal processing by the 'Technical CO Alarm' is undertaken regardless of CO signal processing for the fire detection functionality with the 'Suppression CO' and 'Balanced CO' parameter sets.

The signal processing feature of the 'Technical CO Alarm' enables optimum calculation of the CO concentration. The electro-chemical cell allows the best possible level of accuracy to be obtained depending on the ambient conditions.

The point detector's CO detection is characterized by the ability for parameters to be set and a relatively low cross-sensitivity to other gases, e.g. ethanol or hydrogen (H₂).

Function of the Technical CO Alarm's signal processing

The figure below shows CO signal processing in the form of a diagram:

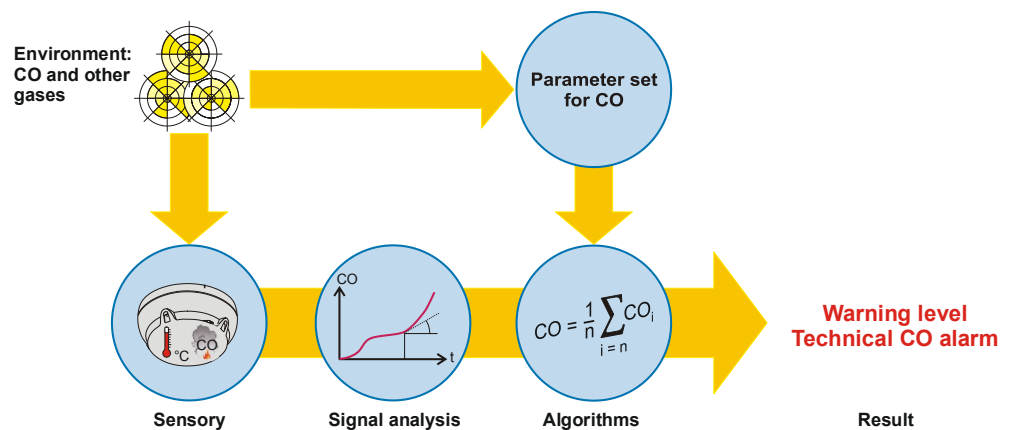

Figure 4: Signal processing by the 'Technical CO Alarm'

Sensory

The signals captured by the CO sensor are corrected with regard to CO exposure, sensor sensitivity, temperature, and aging and supplied to the algorithm. The algorithms are set by selecting the parameter set.

Algorithms

The parameter set can be used to select static and dynamic algorithms. A real time interpretation of the ambient conditions results in improved measurement accuracy.

The alarm limits correspond to the specified or proposed limits in the respective standards.

Switching over of parameter set for the 'Technical CO Alarm'

The point detector allows for the time- or process-controlled independent changing over of the parameter set for CO (Manned / Unmanned changeover). This function allows the detector to be used in places where the situation changes significantly on a regular basis.

Configurable parameter sets for the 'Technical CO Alarm'

The point detector has several permanently programmed 'Technical CO Alarm' parameter sets.

!	NOTICE
	<p>Functionality of the 'Technical CO Alarm'</p> <p>There is a risk of undetected CO exposure if the 'Technical CO Alarm' is not configured on the control panel</p> <ul style="list-style-type: none"> • Use the documentation provided for the fire control panel to ensure that the parameters you want to set for the 'Technical CO Alarm' are supported by the control panel.

!	NOTICE
	<p>The system is not controlled as laid down in EN 54-2</p> <p>Infringement of the EN 54-2 standard</p> <ul style="list-style-type: none"> • The signals for CO detection alone must not be used to control fire detection equipment in accordance with EN 54-2.

3.1.5 Features of the 'Technical Ambient Supervision Message'



'Technical Ambient Supervision Message' mode can only be selected for point detector OOH740 from product version ES ≥20.
The evaluation of the CO concentration in 'Technical Ambient Supervision Message' mode can only be selected for point detector OOHC740.

In 'Technical Ambient Supervision Message' mode, the point detector can detect an increase in temperature or CO concentration above a specified trigger threshold caused by hysteresis.

The control panel is used to configure the parameters.

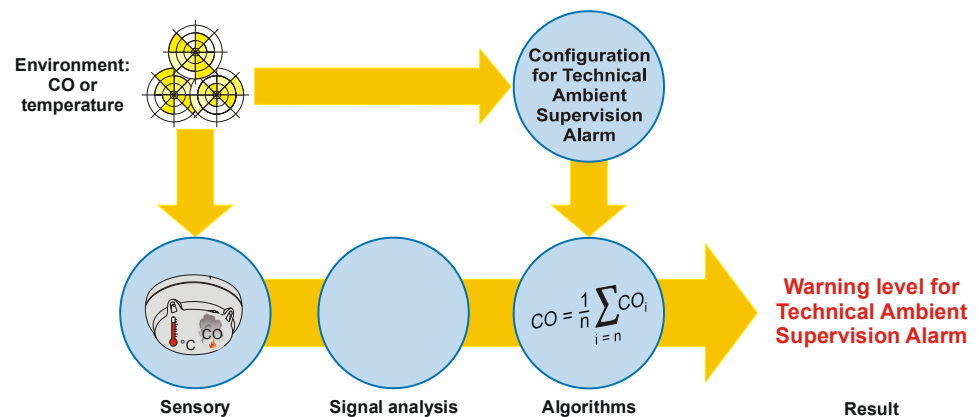

Figure 5: Signal processing by the 'Technical Ambient Supervision Message'



NOTICE

The system is not controlled as laid down in EN 54-2

Infringement of the EN 54-2 standard

- The signals for CO detection or temperature recording must not be used to control fire detection equipment in accordance with EN 54-2.

3.1.6 Details for ordering

Type	Order no.	Designation
OOH740	S54320-F7-A3	Multi-sensor smoke detector, ASA
OOHC740	S54320-F8-A3	Neural fire detector

3.1.7 Product version ES

The product version ES provides the technical status of a device in terms of software and hardware. The product version is provided as a two-digit number.

You will find the details of your device's product version:

- On the packaging label
- On the product label or the type plate

Product version on the packaging label

Details of the product version can be found directly on the packaging label in the barcode:

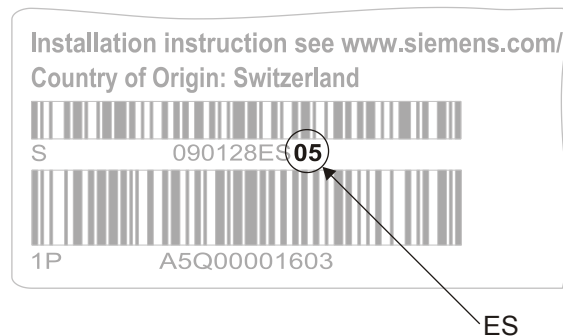

Figure 6: Example of a packaging label with details of the product version

Product version on the product label and the type plate

Details of the product version can be found after the device order number:

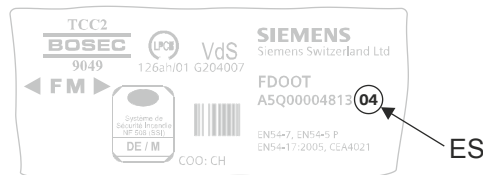

Figure 7: Example of a product label with details of the product version



Depending on the product and various approvals, the product labels may differ in terms of the information type and layout.

Look for your device's order number on the product label.

You will find the product version after the order number.

3.2 Setup

3.2.1 Structure of OOH740

The multi-sensor smoke detector ASA OOH740 is a multi-criteria fire detector and has two optical and two thermal sensors.

Structure and function

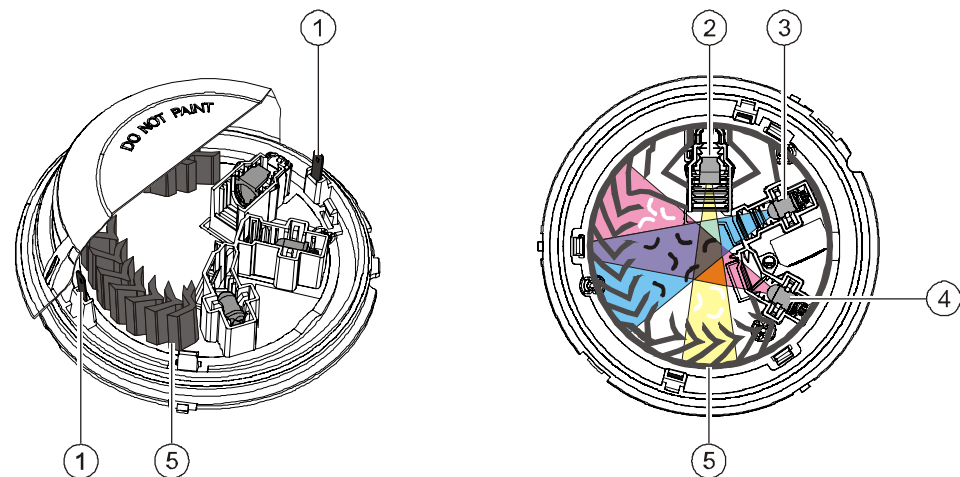

Figure 8: Sensors of the OOH740

- 1 Heat sensors
- 2 Receiver
- 3 Backward scatterer

- 4 Forward scatterer
- 5 Labyrinth

The point detector's high-quality opto-electronic measuring chamber houses the following components:

- Two optical transmitters
- One optical receiver
- Two thermal sensors

The transmitters illuminate the smoke particles from different angles. One sensor acts as forward scatterer, the other as backward scatterer. The scattered light then hits the receiver (photodiode) and generates a measurable electric signal.

The combination of a forward and backward scatterer facilitates an optimum detection and the differentiation of light and dark particles, which leads to a homogenous response behavior and optimizes the differentiation of wanted signals and deceptive phenomena.

In addition, the heat sensors make it possible to detect fires without smoke generation.

The combination of optical and thermal sensor signals optimizes detection reliability. This has the following advantages:

- Early detection of all types of fire, whether they generate light or dark smoke, or no smoke at all.
- The neural fire detector can be operated at a lower sensitivity level and thus achieves a higher immunity against false alarms which can be caused by cold aerosols (e.g. by smoking, electrical welding, etc.). In the case of an open fire, the smoke sensitivity is heightened by the temperature increase, which means that a detection reliability level that is comparable to that of the wide-spectrum smoke detector can be achieved.

Technical Ambient Supervision Message

'Technical Ambient Supervision Message' mode detects an increase in temperature above a specified trigger threshold caused by hysteresis.

You can set the following parameters:

- Temperature threshold value
- Messaging when the temperature threshold value is exceeded or undershot
- Hysteresis range

The 'Technical Ambient Supervision Message' is configured using the 'Cerberus-Engineering-Tool' software.

3.2.2 Structure of OOH740

The neural fire detector OOH740 is a multi-criteria fire detector and has two optical sensors, two thermal sensors, and one CO sensor.

Structure and function

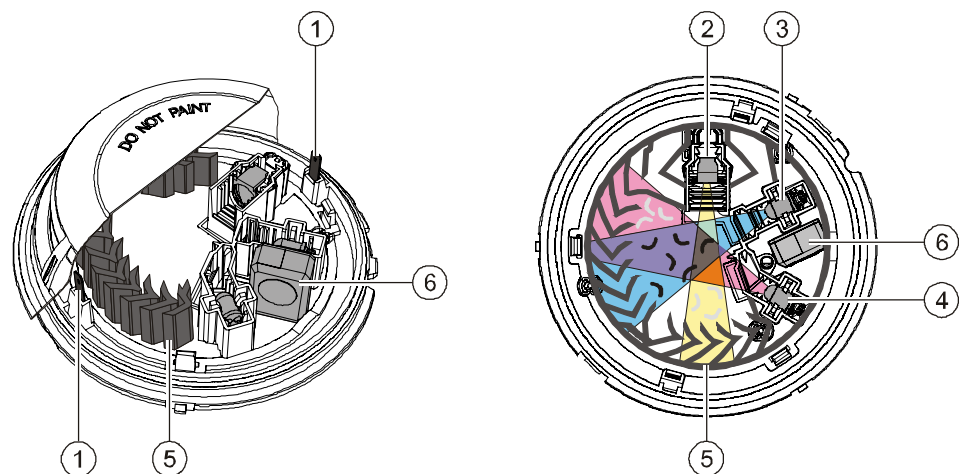

Figure 9: Sensors of the OOH740

- | | |
|----------------------|---------------------|
| 1 Heat sensors | 4 Forward scatterer |
| 2 Receiver | 5 Labyrinth |
| 3 Backward scatterer | 6 CO sensor |

Fire detection

The point detector's high-quality opto-electronic measuring chamber houses the following components:

- Two optical transmitters
- One optical receiver
- Two thermal sensors
- One CO sensor

The transmitters illuminate the smoke particles from different angles. One sensor acts as forward scatterer, the other as backward scatterer. The scattered light then hits the receiver (photodiode) and generates a measurable electric signal.

The combination of forward scatterers and backward scatterers allows for optimum detection of and distinction between light and dark particles and particle sizes. The distinction between light and dark particles firstly results in a homogeneous response behavior and secondly enables better differentiation between wanted signals and deceptive phenomena.

In addition, the heat sensors make it possible to detect fires without smoke generation.

The CO sensor enables faster detection of fires with incomplete combustion and fires with the development of a lot of CO.

The combination of optical, thermal and CO sensor signals optimizes detection reliability for all types of fire, regardless of whether they generate dark or light smoke, or none at all.

You can set the following response behaviors on the neural fire detector OOH740:

- Combined optical and thermal
- Combined optical, thermal and CO
- Optical smoke detector alone
- Heat detector alone

The response behavior is determined by selecting one of the following sensor modes:

- Sensor mode 0: Application as neural fire detector
- Sensor mode 1: Application as heat detector
- Sensor mode 2: Application as smoke detector

The sensor mode is configured with the 'Cerberus-Engineering-Tool' software.



NOTICE

Functionality of sensor modes

Danger of alarm activation as a result of deceptive phenomena

- Depending on the configuration software used for the fire control panel, sensor modes 1 and 2 may not be available.
If the deceptive phenomena occurring (e.g. if the operator suspects that both CO and smoke-like deceptive phenomena are present at the same time) mean that only one heat detector can be operated, the OOH740 may not be used in such environments.

Combined optical-thermal or optical-thermal CO mode is selected by choosing the parameter set in sensor mode 0!

The parameter sets of the heat detector or optical detector can be selected in sensor mode 1 or 2.

Technical CO alarm

The point detector has a high-quality CO sensor which is based on the measurement principle of the electro-chemical cell.

Instances of the specified CO concentration being exceeded can be detected by the CO sensor. The limit values vary depending on the parameters set.

You can set the following CO response behaviors on the neural fire detector OOHC740:

- Static CO alarm thresholds
- Dynamic CO alarm thresholds

The response behavior is configured with the 'Cerberus-Engineering-Tool' software.

Technical Ambient Supervision Message

'Technical Ambient Supervision Message' mode detects an increase in temperature or CO concentration above a specified trigger threshold caused by hysteresis.

Temperature monitoring compares the current measured temperature with a preset threshold value.

CO monitoring compares the current measured CO concentration with a preset threshold value.

You can set the following parameters on the neural fire detector OOHC740:

- CO concentration or temperature threshold value
- Messaging when the temperature threshold value is exceeded or undershot
- Messaging when the CO concentration threshold value is exceeded
- Hysteresis range
 - Fixed hysteresis range
 - Average CO value over a period of 15 minutes

The 'Technical Ambient Supervision Message' is configured using the 'Cerberus-Engineering-Tool' software.

See also

 [Parameter sets \[→ 32\]](#)

3.3 Function

3.3.1 Parameter sets

The detection behavior of the point detectors is influenced by the parameter sets so that it can be specifically adjusted to the fire phenomena and environmental conditions to be expected in the environment to be monitored.

All parameter sets are programmed in the point detectors. During commissioning, the optimum parameter set must be selected for the conditions at the place of installation.



On a C-NET detector line, the parameter set must always be set explicitly.

You can select and set the parameter sets as follows:

- Using the 'Cerberus-Engineering-Tool' software
- Directly on your fire detection system (only within the same sensor mode)

You will find a description of the exact procedure for selecting and setting the parameters in the relevant documentation.



Please note the chapter 'Applicable documents'.

Parameter sets for fire detection in collective mode

The point detector OOH740 can also be operated in collective mode.

There are several parameter sets for fire detection available in collective mode.

The parameter sets are selected in collective mode using resistors installed in the detector base.

See also

- [Parameter set resistor 33 kΩ PSR720-1 \[→ 53\]](#)
- [Parameter set resistance 68 kΩ PSR720-2 \[→ 54\]](#)
- [Connection diagram, collective \[→ 88\]](#)
- [Applicable documents \[→ 9\]](#)

3.3.1.1 Parameter sets for fire detection

The detection behavior of the point detectors is influenced by the parameter sets for fire detection so that it can be specifically adjusted to the fire phenomena and environmental influences to be expected in the environment to be monitored.

All parameter sets for fire detection are programmed in the point detectors. During commissioning, the optimum parameter set must be selected for the conditions at the place of installation.



Always use the suitable parameter set for fire detection for the corresponding application.

The default device parameter set is not always the suitable parameter set.

Overview of parameter sets for fire detection (addressed detector line)

No.	Parameter set sensor mode 0 'Neural fire detector'	OOH740	OOHC740
2	'Robust'	X	X
4	'Balanced'	X	X
5	'Suppression'	X	X
6	'Fast Response'	X	X
7	'High Compensation'	X	X
8	'High Suppression'	X	X
9	'High Sensitive Fast'	X	X
10	'Balanced CO'	–	X
11	'Super Sensitive' ¹	X	–
12	'Suppression CO'	–	X
14	Application-specific parameter sets	–	–
15			

¹ Only from product version ES ≥20



The 'High Suppression', 'High Sensitive Fast', and 'Super Sensitive' parameter sets are only suited for special applications.

No.	Parameter set sensor mode 1 'Heat detector'	OOH740	OOHC740
1	'A1R'	X	X
2	'BR'	X	X
3	'A1S'	X	X
4	'BS'	X	X

No.	Parameter set sensor mode 2 'Smoke detector'	OOH740	OOHC740
1	'Universal'	X	X
2	'Robust'	X	X
3	'Sensitive'	X	X
5	'Super Sensitive' ¹	X	–
6	'Ultra Sensitive' ¹	X	–

¹ Only from product version ES ≥20

X = parameter set can be selected

– = parameter set cannot be selected



The 'Ultra Sensitive' parameter set is only suitable for special applications.



The 'Ultra Sensitive' parameter set does not meet the criteria of standard EN 54-7.

Overview of parameter sets for fire detection (collective detector line)

Parameter set in point detector OOH740	Resistance value in the detector base	Flashing signal to display the set parameter set in the first three minutes following the detector line being started up
'Standard Plus'	-	Once every 6 s
'Suppression'	33 kΩ (resistor PSR720-1)	Twice every 6 s
'High Sensitive Fast'	68 kΩ (resistor PSR720-2)	Three times every 8 s



If there is still a flashing signal on a point detector OOH740 more than 3 minutes after the detector line was started up, there is a fault. You will find more information in chapter 'Internal alarm indicator in the case of ES <20 (OOH740 and OOHC740) [→ 40]'.



The point detector OOH740 is always operated in sensor mode 0 'Neural fire detector' on a collective detector line.



The neural fire detector OOHC740 cannot be operated in collective mode.

See also

- 📖 Parameter sets: Sensor mode 0 'Neural fire detector' [→ 56]
- 📖 Parameter sets: Sensor mode 1 'Heat detector' [→ 60]
- 📖 Parameter sets: Sensor mode 2 'Smoke detector' [→ 60]
- 📖 Parameter sets for collective operation [→ 62]
- 📖 Internal alarm indicator in the case of ES <20 (OOH740 and OOHC740) [→ 40]

3.3.1.2 Parameter sets for 'Technical CO Alarm'

Regardless of the parameter sets for fire detection, the CO detection behavior of the point detector OOH740 can be influenced by the separate parameter sets for CO and specifically adjusted to the environmental influences to be expected in the environment to be monitored.

All parameter sets for CO are programmed in the point detector. During commissioning, the optimum parameter set can be selected for the conditions at the place of installation.

Unlike the parameter sets for fire detection, the parameter set for CO does not necessarily have to be configured. Provided that a fire detection system allows the parameter set for CO to be configured, we would recommend configuring it.



The neural fire detector OOH740 cannot be operated as a pure CO detector. You must always select a parameter set for fire detection as well as the parameter set for CO.

Overview of parameter sets for CO detection

No.	Parameter set	OOH740	OOHC740
0	'Robust EU1'	–	X
1	'Balanced EU2'	–	X
4	'Static 40'	–	X
5	'Static 50'	–	X
6	'Static 60'	–	X
7	'Balanced US1'	–	X

X = parameter set can be selected

– = parameter set cannot be selected

See also

-  Parameter sets for the 'Technical CO Alarm' [→ 66]
-  Configuration [→ 73]

3.3.2 Danger levels and warning levels

3.3.2.1 Danger levels for fire detection

The point detector's signal processing efficiently distinguishes between fire events and deceptive phenomena. If the following points apply, a danger level has been reached:

- Measured values above a response threshold
- Progression of smoke density, temperature and CO concentration (only with OOH740) over a long period of time

The stated parameters are evaluated using algorithms (CO only with the parameter sets 'Suppression CO' and 'Balanced CO').

Danger levels when operating on an addressed detector line (C-NET)

The point detectors can transmit the following danger levels to the fire control panel:

Danger level	Meaning	Comment
0	No danger	Normal condition
1	Check situation	A different parameter set for fire detection should possibly be selected (inappropriate application)
2	Warning	Possible danger
3	Alarm	Fire



The evaluation of the danger level and the decisions to be taken (e.g. activation of remote transmission) are configured in the fire detection system.

Danger levels when operating on a collective detector line

The point detector OOH740 can transmit the following danger levels to the fire control panel:

Danger level	Meaning	Comment
0	No danger	Normal condition
3	Alarm	Fire

3.3.2.2 Warning levels for CO



The functions described in this section are only available on the OOH740.

Measured values above a response threshold depending on the parameter set for CO are not the only basis for reaching a warning level for CO. The CO progression is also observed over a longer period of time and evaluated using algorithms.

Neural fire detector OOH740 can convey the following warning levels to the control panel in the form of a technical message:

Warning level for the Technical CO Alarm	Meaning	Comment
0	No danger	Normal condition
1	Advance warning level 1/ CO loading	Increased CO concentration (MAK value = 30 ppm CO exceeded)
2	Warning	High CO concentration
3	Alarm, evacuation	The CO concentration has reached dangerous levels. This warning level requires parameters to first be set for the CO evaluation. The warning level is not available in degraded mode operation or on devices that have not been commissioned or localized.



The evaluation of the warning level and the decisions to be taken (e.g. activation of remote transmission) are configured in the fire detection system.

3.3.2.3 Danger levels for 'Technical Ambient Supervision Message'

The point detectors can transmit the following danger levels to the fire control panel:

Danger level	Meaning	Comment
0	No danger	Normal condition
2	Warning	Possible danger, threshold value reached



The evaluation of the danger level and the decisions to be taken are configured in the fire detection system.

3.3.3 Diagnosis levels

Operating the point detector on the C-NET:

The point detector monitors its operation largely autonomously. The signals of all sensors are permanently monitored.

The following components in particular should be monitored for correct functionality:

- Temperature sensors
- Light emitters
- Light receivers

The following diagnosis levels are derived from the different control measurements:

- Normal
- Observe information
- Replacement recommended
- Replacement necessary
- Fault

When an error occurs which impairs the correct functionality of the device, a fault message is reported to the control panel.



The CO sensor can only be monitored for failure. For a functional test, the CO sensor must be tested with test gas.

Operating the point detector OOH740 in collective mode:

When an error occurs which impairs the correct functionality of the device, a fault message is reported to the control panel.

- All of the devices installed downstream of the faulty point detector and the end-of-line unit are automatically disconnected.
- A line fault is indicated on the collective control panel.
- The faulty point detector indicates the fault by making the internal alarm indicator flash. Flashing frequency: Two flashes every 4 s.

3.3.4 Line separator

Operating the point detector on the C-NET:

All C-NET devices are equipped with a line separator.

The C-NET device is equipped with electronic switches which isolate the defective part in case of a short-circuit on the C-NET detector line. The rest of the detector line remains serviceable. On a loop line, all C-NET devices remain fully functional after a single short-circuit.



Once the cause of a short-circuit has been remedied on the C-NET, an open line separator does not close automatically. Reset the detector line on the control panel.

3.3.5 Internal alarm indicator in the case of ES <20 (OOH740 and OOHC740)



Information about the product version of your device can be found in the 'Product version ES [→ 27]' chapter.

Addressed mode

The point detectors have an internal alarm indicator. The internal alarm indicator shows the point detector's operating conditions in addressed mode.

Operating condition	Flashing mode of alarm indicator
Normal	AI off
Alarm	AI flashes every second
Test mode	AI off
Alarm in test mode	AI flashes every second



The flashing behavior of the point detectors in addressed mode for higher product versions is described in the 'Advanced flashing behavior of the alarm indicators in the case of ES ≥20 (OOH740 and OOHC740) [→ 41]' chapter.

Collective mode



The flashing behavior of the OOH740 in collective mode is independent from the product version!

The following additional displays are possible when operating the point detector OOH740 in collective mode:

Operating condition	Flashing mode of alarm indicator
Normal	Off
Alarm	Flashing every 1 s
Fault	Two flashes every 4 s
'Standard Plus' parameter set is set	Flash every 6 s ¹
'Suppression'parameter set is set	Two flashes every 6 s ¹
'High Sensitive Fast' parameter set is set	Three flashes every 8 s ¹

¹ Only during the first three minutes of operation after the detector line being started up or reset.

See also

📖 Setting the parameter set in collective operation [→ 64]

3.3.6 External alarm indicator in the case of ES <20 (OOH740 and OOHC740)

External alarm indicators (EAI) connected to the point detectors display the following behavior in addressed mode and collective mode:

Operating condition	Flashing mode of alarm indicator
Alarm/Active	EAI flashes every second
Alarm in test mode	EAI flashes every second



The flashing behavior of the external alarm indicators in addressed mode for higher point detector product versions is described in the 'Advanced flashing behavior of the alarm indicators in the case of ES ≥20 (OOH740 and OOHC740) [→ 41]' chapter.

3.3.7 Advanced flashing behavior of the alarm indicators in the case of ES ≥20 (OOH740 and OOHC740)

Internal alarm indicators

The table below describes the flashing behavior of internal alarm indicators in addressed mode.

You will find information on the flashing behavior of the OOH740 in collective mode in chapter 'Internal alarm indicator in the case of ES <20 (OOH740 and OOHC740) [→ 40]'.



Several flashing patterns are available for normal operation. The flashing pattern is selected using the 'Cerberus-Engineering-Tool' software.

Operating condition	Flashing mode	Graphic
Alarm Display priority: 1	IAI flashes red once a second	
Test mode Display priority: 1	Without alarm	
	With alarm	
Fault 1 Display priority: 2	IAI off	
Normal Display priority: 3	Configuration 1 (device default)	
	Configuration 2	

1 Or 'Configuration 1' mode active.

The display priority ensures that important messages are prioritized in the flashing behavior. Highest display priority: 1.

Example: If a detector is displaying 'Fault' and then an alarm is detected, the flashing mode will change from 'Fault' to 'Alarm'.



Not all fire control panels support the flashing patterns described.



A steady-on flashing mode for the alarm and an alternative flashing mode for normal operation can be set using the 'Cerberus-Engineering-Tool' software.



The above graphics are not valid in countries in which the alarm is indicated by an alarm indicator that lights up permanently. For more information, please contact your regional company.

Please also observe the documentation for your fire detection system.

External alarm indicators

The table below describes the flashing behavior of external alarm indicators in combination with a point detector whose product version corresponds to the title of this chapter in addressed mode.

Operating condition		Flashing mode	Graphic
Alarm/Active Display priority: 1		EAI flashes red every second	
Fault ¹ Display priority: 2		EAI off	
Normal Display priority: 3	Configuration 1 (device default)	EAI off	
	Configuration 2	EAI flashes red every 10 seconds	

¹ Or 'Configuration 1' mode active.

The display priority ensures that important messages are prioritized in the flashing behavior. Highest display priority: 1.

Example: If a detector is displaying 'Fault' and then an alarm is detected, the flashing mode will change from 'Fault' to 'Alarm'.



Information about the product version of your point detector can be found in the 'Product version ES [→ 27]' chapter.

3.3.8 Connection for external alarm indicators

Operating the point detector on the C-NET:

Two external alarm indicators can be connected to each point detector.



On the C-NET, it is possible to connect external alarm indicator to any point detector. The trigger for activating the alarm indicator can be programmed at the control panel.

Instead of an optical alarm indicator that flashes in the event of an alarm, the sounder base is provided with an acoustic alarm indicator.

Operating the point detector OOH740 in collective mode:

The external alarm indicator is activated in the event of an alarm. Two external alarm indicators can be connected to the point detector OOH740.

See also

-  Sounder base DBS720 [→ 50]
-  Connection diagram, addressed [→ 86]
-  Connection diagram, collective [→ 88]

3.3.9 Renovation mode

When operating the point detectors on the C-NET, individual detectors can be set specifically to renovation mode on the fire control panel.

Select renovation mode if major work is being carried out in the room and large volumes of dust or aerosols are being produced.

In renovation mode, the neural fire detector and the heat detector only trigger an alarm when the temperature exceeds 80 °C for 20 seconds.



The wide-spectrum smoke detector does not respond to smoke in renovation mode. When a temperature of 80 °C is reached for a period of 20 s, the wide-spectrum smoke detector does however also send an alarm to the control panel.



Renovation mode cannot be selected in collective operation.

3.3.10 Test mode

Operating the point detector on the C-NET:

For testing purposes the point detectors can be set to test mode. In test mode the point detectors react faster and with a higher sensitivity level.

Physical testing:

- The optical function part on the neural fire detector can also be tested with the test gas REF8 or REF8-S.
- The heat sensors of the neural fire detector can be tested with the following accessories:
 - Hot air fan
 - RE7T Solo461 heat detector tester kit
- The CO sensor can be tested with the test gas REF8-C.

Operating the point detector OOH740 in collective mode:

Once the point detector has been inserted into the detector base or once the detector line has been reset, the point detector works in test mode for a period of 3 minutes.

The 'Test mode' status is displayed on the point detector's internal alarm indicator. The internal alarm indicator displays the parameter set selected at the present moment.

During this time, the point detector's response time is considerably reduced. This makes it easier to test the point detector with test gas.

See also

- 📄 Internal alarm indicator in the case of ES <20 (OOH740 and OOHC740) [→ 40]
- 📄 Setting the parameter set in collective operation [→ 64]
- 📄 Testing the point detector [→ 96]

3.3.11 Behavior in degraded mode

Applicable for the C-NET:

When the main processor of the fire control panel fails, the control panel works in degraded mode operation. Depending on the control panel type, the fire control panel can continue to perform the most important alarming and signaling functions in degraded mode operation.

Behavior of control panels that support degraded mode operation:

- Alarming is still ensured in degraded mode operation. However, in degraded mode only collective alarming is possible. This means that in the event of an alarm, it is possible to identify the C-NET detector line but not the exact location of the detector triggering the alarm.
- If a sounder base DBS720 is connected to the output for the external alarm indicator, it is activated in degraded mode operation in the event of a fire alarm.
- When the connection for the external alarm indicator is used for a control function (e.g. hold-open system), the output assumes the configured fail-safe position; configuration for a specific control panel is possible.



In degraded mode operation, the OOH740 only supports the 'Fire' alarm class. If the 'CO' alarm class is also to be supported in degraded mode operation, please contact technical customer support.

Degraded mode operation on the C-NET is not supported in the same way by all control panels. The information in the 'List of compatibility' and in the corresponding control panel documentation must be taken into account during project planning.



Degraded mode operation is not possible on collective detector lines.

3.3.12 Line tester

The line tester FDUL221 is able to recognize and localize the following errors on the C-NET:

- Wiring error
- Open line
- Short-circuit
- Ground fault

In addition, the line tester recognizes the devices connected to the C-NET detector line.

You will find more information in document 008250.



The line tester FDUL221 cannot be used on collective detector lines.

See also

Applicable documents [→ 9]

3.4 Mechanical setup

One of the following devices is required to install a point detector:

- Detector base DB72x or detector base (collective) DB110
- Sounder base DBS720

After installing the detector base or sounder base, simply insert the point detector in the base and turn it, either manually or using the detector exchanger DX791 and the adapter for detector exchanger FDUD491, until you hear and feel it snap in.

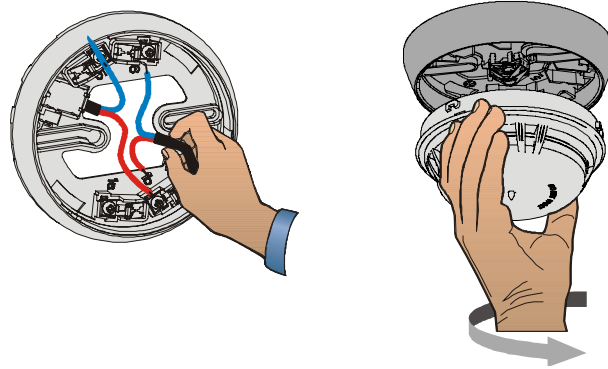

Properties

- Quick installation and secure contact
- The centered alarm indicator makes an alignment of the detector base superfluous
- Space for up to 4 auxiliary terminals

Accessories are available for a variety of different applications and can be combined to suit the particular application in question.

See also

- 📄 Detector base with loop contact DB721 [→ 47]
- 📄 Detector base DB721D [→ 49]
- 📄 Detector base (collective) DB110 [→ 49]
- 📄 Sounder base DBS720 [→ 50]

3.5 Accessories

3.5.1 Detector base with loop contact DB721

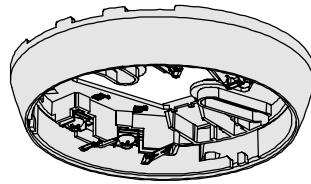

- For the mounting of point detectors
- Thanks to the loop contacts, the detector line is not interrupted when there is no point detector installed in the detector base.
- For the recess-mounted cable entry
- For surface-mounted cable entry, up to 8 mm cable diameter
- Cable connection via screw terminals
- Compatible with:
 - Multi-sensor fire detector OH720
 - Smoke detector OP720
 - Heat detector HI720
 - Heat detector HI722
 - Multi-sensor smoke detector, ASA OOH740
 - Neural fire detector OOHC740
 - Interbase DBS72x
 - Air sampling smoke detection kit FDBZ290
- Order number: S54319-F11-A1

See also

- 📄 Detector base DB72x and detector base (collective) DB110 [→ 75]
- 📄 Cable entry [→ 85]

3.5.2 Detector base DB722

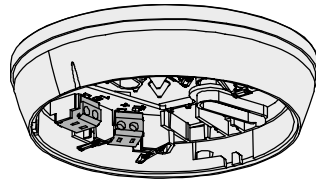

- For the mounting of point detectors
- Thanks to the loop contacts, the detector line is not interrupted when there is no point detector installed in the detector base.
- For the recess-mounted cable entry
- For surface-mounted cable entry, up to 8 mm cable diameter
- Seal integrated in the detector base. Protection category: IP42.
- Cable connection via spring clips
- Compatible with:
 - Multi-sensor fire detector OH720
 - Smoke detector OP720
 - Heat detector HI720
 - Heat detector HI722
 - Multi-sensor smoke detector, ASA OOH740
 - Neural fire detector OOH740
- Order number: S54319-F19-A1

See also

- 📄 Detector base DB72x and detector base (collective) DB110 [→ 75]
- 📄 Cable entry [→ 85]

3.5.3 Detector base DB721D

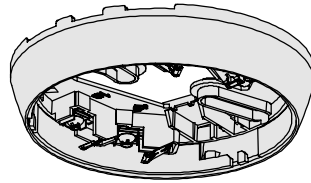

- For installing point detectors in collective operation
- Removable diode unit: A collective detector line can be converted on the C-NET by removing the diode unit without changing the detector base
- Thanks to the diode unit, the collective detector line is not interrupted when there is no point detector installed in the detector base. A compatible control panel can detect and display that the point detector is missing.
- For the recess-mounted cable entry
- For surface-mounted cable entry, up to 8 mm cable diameter
- Cable connection via screw terminals
- Compatible with:
 - Multi-sensor smoke detector, ASA OOH740
 - Air sampling smoke detection kit FDBZ290
- Order number: S54319-F15-A1

See also

- 📄 Detector base DB72x and detector base (collective) DB110 [→ 75]
- 📄 Cable entry [→ 85]

3.5.4 Detector base (collective) DB110

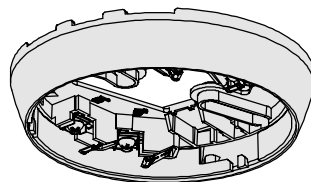

- For the mounting of point detectors
- The detector line is interrupted if the point detector is not used
- Selects the default device parameter set in the point detector used
- For the recess-mounted cable entry
- For surface-mounted cable entry, up to 8 mm cable diameter
- Compatible with:
 - Multi-sensor smoke detector, ASA OOH740
 - Air sampling smoke detection kit FDBZ290
- Order number: S54372-F5-A1

See also

- 📄 Detector base DB72x and detector base (collective) DB110 [→ 75]
- 📄 Cable entry [→ 85]

3.5.5 Sounder base DBS720

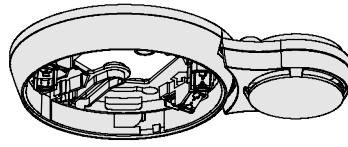

- For acoustic alarming in the case of an event
- Thanks to the loop contacts, the detector line is not interrupted when there is no point detector installed in the sounder base.
- For the C-NET detector line
- For the recess-mounted cable entry
- For surface-mounted cable entry, up to 8 mm cable diameter
- Compatible with:
 - Multi-sensor fire detector OH720
 - Smoke detector OP720
 - Heat detector HI720
 - Heat detector HI722
 - Multi-sensor smoke detector, ASA OOH740
 - Neural fire detector OOH740
- You will find more information in document A6V10218037
- Order number: S54319-F5-A1

See also

- 📄 Sounder base DBS720 [→ 77]
- 📄 Cable entry [→ 85]

3.5.6 Designation plate FDBZ291

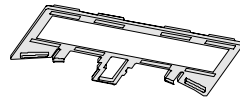

- To identify the location
- Compatible with:
 - Detector base DB72x
 - Sounder base DBS720
- Order number: A5Q00002621

See also

- 📄 Designation plate FDBZ291 [→ 84]

3.5.7 Detector base seal RS720

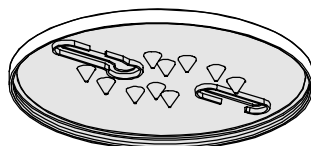

- For mounting in wet rooms
- Protection category IP42
- Compatible with:
 - Detector base DB72x
 - Sounder base DBS720
- Order number: S54319-F8-A1

See also

- 📄 Detector base seal RS720 [→ 78]

3.5.8 Base attachment BA720

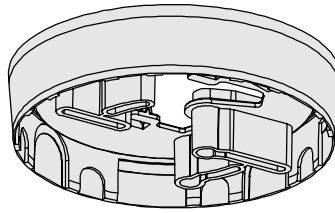

- There are several potential break-out points in the base attachment for surface-mounted cable entry
- For the recess-mounted cable entry
- Permanent connection and joint mounting with detector base
- Compatible with:
 - Detector bases DB72x
- Order number: S54319-F20-A1

See also

📄 Base attachment BA720 [→ 79]

3.5.9 Base attachment wet BA721

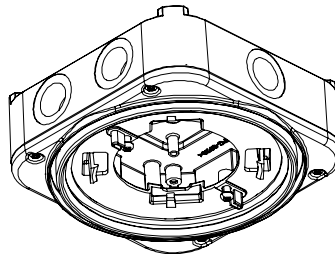

- For mounting in humid, wet environments and if the detector heating unit is used
- Protection category achievable: IP44
- Six break-out points for M20 x 1.5 metal cable glands
- Compatible with:
 - Detector base DB72x/DB110xx/DB721D
 - Detector heating unit FDBH291
 - Designation plate DBZ1193A
 - M20 x 1.5 metal cable gland
- Order number: S54319-F29-A1

See also

📄 Base attachment wet BA721 [→ 80]

3.5.10 Designation plate DBZ1193A

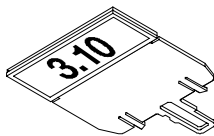

- To identify the location
- Compatible with:
 - Base attachment wet FDB295/BA721
 - Base attachment, surface-mounted, humid DBZ1192
 - DBW1171 base
 - Interbase DBS72x
- Order number: BPZ:4864330001

See also

📄 Base attachment wet BA721 [→ 80]

3.5.11 Detector heating unit FDBH291

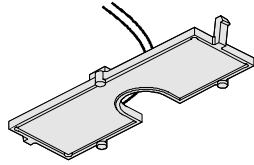

- For operating point detectors in critical ambient conditions during icy conditions or when there is a danger of moisture condensation
- Compatible with:
 - Addressable detector base FDB2x1/FDB2x1-AA
 - Flat detector base FDB2x2
 - Base attachment wet FDB295/BA721
- Order number: A5Q00004439

See also

 Detector heating unit FDBH291 [→ 91]

3.5.12 Protective cage DBZ1194

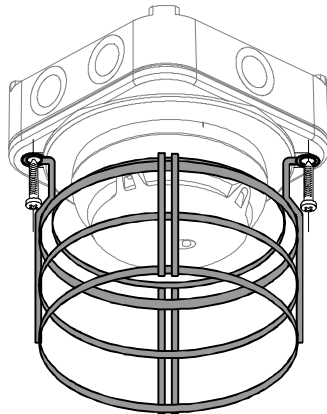

- To protect the devices against mechanical damage
- Can only be used in conjunction with the following accessories:
 - Base attachment wet FDB295
 - Base attachment wet BA721
- Order number: BPZ:4677110001

See also

 Base attachment wet BA721 [→ 80]

3.5.13 Detector locking device LP720

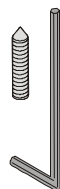

- For protection against theft
- Compatible with:
 - Multi-sensor fire detector OH720
 - Smoke detector OP720
 - Heat detector HI720
 - Heat detector HI722
 - Multi-sensor smoke detector, ASA OOH740
 - Neural fire detector OOH740
 - Interbase DB72x
- Order number: S54319-F9-A1

See also

 Detector locking device LP720 [→ 83]

3.5.14 Micro terminal DBZ1190-AA

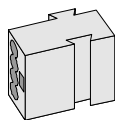

- Auxiliary terminal for connecting cables
- For T-branches of additional cabling e.g. for detector heating units, sounder base, external alarm indicators etc.
- For conductor cross-sections of 0.28...0.5 mm²
- 4-pin
- Order number: BPZ:4677080001

3.5.15 Connection terminal DBZ1190-AB

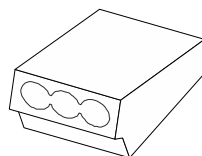

- Auxiliary terminal for connecting cables
- For T-branches of additional cabling, e.g., for cable shielding, detector heating units, sounder base, external alarm indicators, etc.
- For conductor cross-sections of 1...2.5 mm²
- 3 poles
- Order number: BPZ:4942340001

3.5.16 Parameter set resistor 33 kΩ PSR720-1

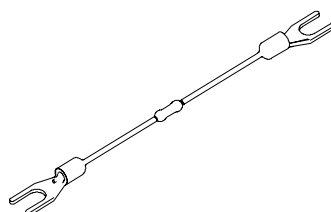

- For selecting the 'Suppression' parameter on a point detector OOH740 in collective mode
- Resistance value: 33 kΩ
- Install the resistors directly in a detector base DB721D or detector base (collective) DB110 between terminals '5' and '1a'
- Compatible with:
 - Multi-sensor smoke detector, ASA OOH740
- Order number: S54319-F16-A1

See also

 Connection diagram, collective [→ 88]

3.5.17 Parameter set resistance 68 k Ω PSR720-2

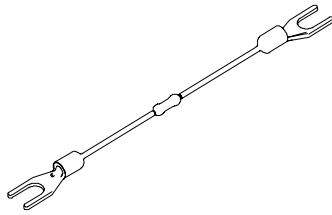

- For selecting the 'High Sensitive Fast' parameter set on a point detector OOH740 in collective mode
- Resistance value: 68 k Ω
- Install the resistors directly in a detector base DB721D or detector base (collective) DB110 between terminals '5' and '1a'
- Compatible with:
 - Multi-sensor smoke detector, ASA OOH740
- Order number: S54319-F17-A1

See also

- 📄 Connection diagram, collective [→ 88]

4 Planning

4.1 Compatibility

Compatible with control panels that support the C-NET detector line.

The point detector OOH740 is also compatible with control panels which support collective mode.

You will find detailed information in the 'List of compatibility'.

The table below shows the compatibility of the devices with various product lines:

Detector line	Control panels						
	FC20xx	FC10	FC12x	FC72x	SIGMASYS	AlgoRex	XC10
C-NET	–	–	–	X	–	–	–
Collective	–	X ¹⁾	X ¹⁾	X ^{1) 2)}	–	–	X ¹⁾

X = compatible

– = not compatible

¹⁾ OOH740 only

²⁾ Connection only possible via suitable line devices, e.g., input/output module (transponder) FDCIO223 or zone module FDCI723

4.2 Fire detection

4.2.1 Ambient features

In selecting the optimum fire alarm parameter set, the following factors must be taken into account:

- Risk of damage to persons
- Value concentration
- Room geometry
- Deceptive phenomena
- Risk of fire
- Critical fire size

Risk of damage to persons

People's lives are severely at risk in venues such as concert halls, nursing homes, and hospitals. The risk of damage to persons is therefore very high in such places. In canteen kitchens the situation is different. Few people work in such facilities and are able to save themselves in the event of timely alarms. The risk of damage to persons is thus rather low in this case.

Value concentration

Irreplaceable cultural assets are often on display in museums. Computer centers house servers with large data volumes. The concentration of valuable items is rather high. In a normal hotel room the concentration of valuable items must be classified as low.

Room geometry

High ceilings, complex room shapes or well-ventilated rooms have a complex room geometry. This aggravates early fire detection, as it is difficult for the fire phenomenon to reach the fire detector. An office room with normal ceiling height has a simple room geometry.

Deceptive phenomena

Deceptive phenomena can deceive a fire detector and bring about a false alarm. The deceptive phenomena differ depending on the fire detector. Deceptive phenomena include

- Steam
- Cigarette smoke
- Dust
- Dry ice in discotheques
- Exhaust fumes
- Aerosols produced when welding
- Sources of heat such as radiant heaters or hot engines

In a small hotel room with a rather low ceiling where vapor from the bathroom may penetrate the room, or in operating facilities where a lot of dust is generated, many deceptive phenomena must be taken into consideration. In a clean room where electronic modules are fabricated the risk of deceptive phenomena is rather low.

Risk of fire

In production facilities where highly combustible materials such as flammable liquids, cotton, paper etc. are processed and where electrical machines are operated, the fire risk is very high. Minor overheating or sparks may cause a fire. In a storehouse where steel is stored and where no electrical installation is provided with the exception of lighting, the fire risk is very low.

Critical fire size

When a waste paper basket in a metal-processing facility catches fire, the consequential damage is usually rather low. Here we are talking about a critical, medium fire size that can still be tolerated. The situation is completely different in pharmaceutical production facilities where even the lowest smoke concentration may impair the process and where combustible materials are processed. Even the smallest fire must be detected immediately. In this case, we are talking about a small admissible critical fire size.

4.2.2 Parameter sets: Sensor mode 0 'Neural fire detector'

4.2.2.1 Description

(Parameter set numbers in brackets)

High Suppression (8):

To cover applications with permanent, optical deceptive phenomena (dry ice in discotheques, welding), this parameter set only reacts when a temperature rise of approx. 8 K is detected in addition to the optical signal. Due to the combination of optical and thermal signals, it is better suited than a pure heat detector. This parameter set is also suited for applications that can otherwise only be covered with special detectors.

Suppression (5):

Thanks to its very robust behavior, the 'Suppression (5)' parameter set is particularly suitable for rooms where deceptive phenomena such as vapor, very dense cigarette smoke or exhaust fumes can be expected. It reacts in a very robust way to the deceptive phenomenon vapor.

Suppression CO (12):

Thanks to its very robust behavior, this parameter set is particularly suited for rooms where deceptive phenomena such as vapor, cigarette smoke or exhaust fumes can be expected. It reacts in a very robust way to the deceptive phenomenon vapor. In the event of smoldering fires or fires in rooms where cleaning products are stored, the parameter set reacts quicker than the 'Suppression (5)' parameter set as it takes the CO concentration into account.

High Compensation (7):

This parameter set reacts in the same way as the 'Robust (2)' parameter set, however, the compensation range is twice as large. This parameter set is thus especially suited for rooms in which a lot of dust and other deposits can be expected during longer periods.

Robust (2):

The priority of the 'Robust (2)' parameter set is on robust response. The sensitivity is the same as with the 'Suppression (5)' parameter set; however, deceptive phenomena are not explicitly analyzed and suppressed. It is thus particularly suited to application in rooms where deceptive phenomena such as cigarette smoke or dust can be expected. The 'Robust (2)' parameter set is suitable for higher rooms in comparison to the 'Suppression (5)' parameter set.

Balanced (4):

The 'Balanced (4)' parameter set displays a balanced response behavior in its response to fires and robustness to deceptive phenomena. It reacts faster with open fires. It reacts slower with vapor, cigarette smoke or smoldering fires.

Balanced CO (10):

This parameter set displays a balanced response behavior in its response to fires and robustness to deceptive phenomena. It reacts faster with open fires. It reacts slower with vapor and cigarette smoke. In the event of smoldering fires or fires in cleaning rooms, the parameter set reacts quicker than the 'Balanced (4)' parameter set as it takes the CO concentration into account.

Thanks to the fact that three criteria are evaluated (smoke, heat and CO concentration), this gives particular robustness to deceptive phenomena when compared with more sensitive parameter sets.

Fast Response (6):

This parameter set reacts in a fast and highly sensitive manner. It is thus especially suitable for rooms without deceptive phenomena, where the priority is on detecting the fire as early as possible.

High Sensitive Fast (9):

This parameter set is suited for applications requiring very high sensitivity levels. It reveals a significantly higher optical and thermal sensitivity than 'Fast Response'. This parameter set is also suited for applications that can otherwise only be covered with special detectors.

Super Sensitive (11):

This parameter set can be selected for all point detectors OOH740 from product version ES ≥20.

The parameter set is suitable for applications that require fast and sensitive response behavior. It is twice as sensitive as 'High Sensitive Fast' in detecting smoldering fires and temperature increases. Its response behavior with respect to smoldering fires is similar to that of the 'Sensitive' parameter set.

Download 1 (14) / download 2 (15):

Application-specific parameter sets that can be loaded directly onto the point detector.



All parameter sets except for 8 comply with standards EN 54-7 and CEA 4021.



Parameter sets 'Balanced CO' and 'Suppression CO' do not have LPCB approval.

4.2.2.2 Use

No.	Name	Risk of damage to persons	Concentration of valuable items	Room geometry	Deceptive phenomena	Risk of fire	Critical fire size
		small... large	low... high	simple... complex	few... many	small... large	small... medium
8	'High Suppression'						
5	'Suppression'						
12	'Suppression CO'						
7	'High Compensation'						
2	'Robust'						
4	'Balanced'						
10	'Balanced CO'						
6	'Fast Response'						
9	'High Sensitive Fast'						
11	'Super Sensitive'						



The 'High Suppression', 'High Sensitive Fast', and 'Super Sensitive' parameter sets are only suited for special applications.

4.2.2.3 Specification

The following table shows the characteristics and fields of application of the parameter sets of the point detectors OOH740 and OOH740.

No.	Name	Optical			Thermal		
		Typ. Response time from - typ. - to	Sensitivity, open fire	Sensitivity, smoldering fire	Static activation temperature	Differential activation temperature (temperature increase >10 K/min)	Differential activation possible from:
		[s]	[%/m]	[%/m]	[°C]	ΔT [K]	[°C]
8	'High Suppression'	60 - 80 - 360	2.3	8	80	25	30
5	'Suppression' ²	90 - 160 - 760	3.2	11.4	80	29	30
12	'Suppression CO' ¹	75 - 150 - 760	2.3...3.2 ⁴	8.6...11.4 ³	80	29	30
7	'High Compensation'	80	3.2	11.4	80	29	30
0	'High Compensation'	80	3.2	11.4	80	29	30
2	'Robust'	80	3.2	11.4	80	29	30
4	'Balanced'	40 - 64 - 300	2.3	8	80	25	30
10	'Balanced CO' ¹	25 - 50 - 300	1.4...2.3 ⁴	5...8 ³	80	25	30
6	'Fast Response'	20 - 30	1.6	5.6	80	22	3
9	'High Sensitive Fast'	20 - 30	0.8	2.8	60	16	3
11	'Super Sensitive' ⁵	12	1.0	1.5	60	8	3
14	Application-specific parameter sets						
15							

- ¹ The CO signal helps to speed up alarm activation in the event of smoldering fires but cannot trigger fire alarms on its own.
- ² Only for OOH740: If the 'Suppression (5)' parameter set is needed, 'Suppression CO (12)' should be used for new applications.
- ³ Depends on CO proportion.
- ⁴ In the case of open fires, the proportion of CO in the fire gas make-up is low. With high proportions of CO, the sensitivity could theoretically increase by up to 0.9 %/m with open fires (i.e. instead of 2.3 %/m to 1.4...2.3 %/m, for example).
- ⁵ Only in the OOH740 from ES ≥20



The static activation temperature of 80 °C is above the operating temperature range permissible for continuous periods.
The point detector may only be used in continuous operation within the specified temperatures!

4.2.3 Parameter sets: Sensor mode 1 'Heat detector'

Select 'Sensor mode 1' 'Heat detector' if the detector should only react thermally.

No.	Name
0	'A1R'
1	'A1R'
2	'BR'
3	'A1S'
4	'BS'



All parameter sets meet the criteria of standard EN 54-5.

4.2.4 Parameter sets: Sensor mode 2 'Smoke detector'

4.2.4.1 Description

Select sensor mode 2 when fast temperature changes may occur which are not caused by fire (e.g. radiant heaters, hot engines). In this sensor mode the detector only reacts optically; this is comparable with a wide-spectrum smoke detector. However, because it has a second optical sensor, it reveals an optimized response behavior in relation to the different types of fire.

(Parameter set numbers in brackets)

Robust (2):

This parameter set responds to aerosols in a similar way as the neural fire detector in sensor mode 0 with the 'Robust' parameter set, without taking into account the temperature.

Universal (1):

With 'Universal' the sensitivity and response time to aerosols are between 'Robust' and 'Sensitive'.

Sensitive (3):

With regard to aerosols, this parameter set reacts in a way that is comparable to 'Fast Response' in sensor mode 0 without temperature influence.

Super Sensitive (5):

The parameter set can be selected for all point detectors OOH740 from ES ≥ 20 .

With regard to aerosols, this parameter set reacts in a way that is comparable to the 'Super Sensitive' parameter set in sensor mode 0 without temperature influence.

Ultra Sensitive (6):

The parameter set can be selected for all point detectors OOH740 from ES ≥ 20 .

This parameter set has an extremely high level of sensitivity for normal smoke detectors. Only select 'Ultra Sensitive' for applications that require high sensitivity and where no deceptive phenomena (visible aerosols) can be expected.



With the exception of '6', all parameter sets meet the criteria of standard EN 54-7.

4.2.4.2 Use

No.	Name	Risk of damage to persons	Concentration of valuable items	Room geometry	Deceptive phenomena	Risk of fire	Critical fire size
		small ... large	low ... high	simple ... complex	few ... many	small ... large	small ... medium
2	'Robust'						
1	'Universal'						
3	'Sensitive'						
5	'Super Sensitive'						
6	'Ultra Sensitive'						

4.2.4.3 Specification

The table below shows the parameter sets' characteristics and fields of application:

No.	Name	Response time [s]	Sensitivity open fire/smoldering fire [%/m]
2	'Robust'	80	2.3 / 8
1	'Universal'	50	2.3 / 8
0	'Universal'	50	2.3 / 8
3	'Sensitive'	30	1.6 / 5.6
5 ¹	'Super Sensitive'	12	1.0 / 1.5
6 ¹	'Ultra Sensitive'	12	0.35 / 0.5

¹ Only in the OOH740 from ES ≥20

4.2.5 Parameter sets for collective operation



Collective mode is only possible with the point detector OOH740.

4.2.5.1 Description

Standard Plus:

This parameter set is fast and highly sensitive. It is thus especially suited to rooms without deceptive phenomena, where the priority is on early fire detection.

Suppression:

Thanks to its very robust behavior, the 'Suppression' parameter set is particularly suitable for rooms where deceptive phenomena such as cigarette smoke or exhaust fumes can be expected. It reacts in a very robust way to the deceptive phenomenon vapor.

High Sensitive Fast:

This parameter set is suited for applications requiring very high sensitivity levels. It is also suitable for applications that can otherwise only be covered with special detectors.

4.2.5.2 Use

Name	Risk of damage to persons	Concentration of valuable items	Room geometry	Deceptive phenomena	Risk of fire	Critical fire size
	small ... large	low ... high	simple ... complex	few ... many	small ... large	small ... medium
'Standard Plus'						
'Suppression'						
'High Sensitive Fast'						

4.2.5.3 Specification

Name	Optical			Thermal	
	Typ. Response time from - typ. - to	Sensitivity, open fire	Sensitivity, smoldering fire	Static activation temperature	Differential activation temperature ¹
	[s]	[%/m]	[%/m]	[°C]	ΔT [K]
'Standard Plus'	50	2.3	8	80	25
'Suppression'	90 - 160 - 760	3.2	11.4	80	29
'High Sensitive Fast'	20 - 30	0.8	2.8	60	16

¹ Applicable with fast temperature increases >10 K/min.



The static activation temperature of 80 °C is above the operating temperature range permissible for continuous periods. The point detector may only be used in continuous operation within the specified temperatures!

4.2.6 Default settings for operating on the C-NET

The default device parameter set is set in the following cases:

- Point detector has not been commissioned
- Device location cannot be localized (e.g., due to a fault)

The device parameter set 0 is set with sensor mode 0 in the point detectors OOH740 and OOHC740 when delivered.

The following table shows the default device parameter set in the various sensor modes.

Fire detectors OOH740 / OOHC740	Default device parameter set
Sensor mode 0 (neural fire detector)	'High Compensation'
Sensor mode 1 (heat detector)	'A1R'
Sensor mode 2 (smoke detector)	'Universal'

Upon commissioning of the fire detection system, the optimum parameter set must be selected based on the existing risk and the ambient conditions.

After the commissioning of the control panel, the fire detectors are automatically set to their country-specific basic setting.

You can select and set the parameter sets as follows:

- Using the 'Cerberus-Engineering-Tool' software
- Directly on your fire detection system (only within the same sensor mode)

You will find a description of the exact procedure for selecting and setting the parameters in the relevant documentation.



Please note the chapter 'Applicable documents'.

See also

Applicable documents [→ 9]

4.2.7 Setting the parameter set in collective operation

In the case of the point detector OOH740, the set parameter set depends on the resistor installed in the detector base.

Parameter set in fire detector OOH740	Resistance value in the detector base	Flashing signal to display the set parameter set in the first three minutes following the detector line being started up
'Standard Plus'	-	Once every 6 s
'Suppression'	33 kΩ (PSR720-1)	Twice every 6 s
'High Sensitive Fast'	68 kΩ (PSR720-2)	Three times every 8 s

If no resistor is installed in the detector base, the 'Standard Plus' parameter set is set.

Upon commissioning of the fire detection system, the optimum parameter set must be selected based on the existing risk and the ambient conditions.

See also

- 📖 Internal alarm indicator in the case of ES <20 (OOH740 and OOHC740) [→ 40]
- 📖 Parameter set resistor 33 kΩ PSR720-1 [→ 53]
- 📖 Parameter set resistance 68 kΩ PSR720-2 [→ 54]

4.2.8 Sample applications for OOH740

The table below includes examples regarding the selection of the parameter set for the point detector. The examples cannot be used universally, but illustrate typical applications.

Environment	Deceptive phenomena / detector behavior	Parameter set	
		Addressed	Collective
Normal office, room without any particular deceptive phenomena	No special requirements	'High Compensation (7)'	'Standard Plus'
Possible deceptive phenomena, e.g. electric kettle	Vapor as deceptive phenomenon	'Balanced (4)' or 'Suppression (5)'	'Suppression'
Kitchen	A lot of vapor as deceptive phenomenon	'Suppression (5)' or 'BS (4)'	'Suppression'
Hospital room, museum	Quick response needed, no deceptive phenomena expected	'Fast Response (6)'	'Standard Plus'
Clean room	Fast and very sensitive reaction required	'High Sensitive Fast (9)'	'High Sensitive Fast'

4.2.9 Sample applications for OOH740

The table below includes examples regarding the selection of the parameter set for the point detector. The examples cannot be used universally, but illustrate typical applications.

Environment	Deceptive phenomena / detector behavior	Parameter set
Normal office, room without any particular deceptive phenomena	No special requirements	'Robust (2)' in sensor mode 0
Rooms with potential risk to persons due to smoldering fires, CO development	–	'Balanced CO (10)' Alternatively 'Balanced (4)'
Possible deceptive phenomena, e.g. electric kettle	Vapor as deceptive phenomenon	'Balanced CO (10)' or 'Suppression CO (12)' Alternatively 'Balanced (4)' or 'Suppression (5)'
Cleaning rooms (e.g. in hotels)	Vapors from cleaning materials	'Balanced CO (10)' Alternatively 'Balanced (4)'
Kitchen	A lot of vapor as deceptive phenomenon	'Suppression CO (12)' or 'Balanced CO (10)' Alternatively 'Suppression (5)' or 'Balanced (4)'
Hospital room, museum	Quick response needed; no deceptive phenomena expected	'Fast Response (6)'
Clean room	Fast and very sensitive reaction required	'High Sensitive Fast (9)'

4.3 Technical CO alarm



The 'Technical CO Alarm' mode can only be selected on the neural fire detector OOH740.



NOTICE

The system is not controlled as laid down in EN 54-2

Infringement of the EN 54-2 standard

- The signals for CO detection or temperature recording must not be used to control fire detection equipment in accordance with EN 54-2.

4.3.1 Parameter sets for the 'Technical CO Alarm'

4.3.1.1 Description

(Parameter set numbers in brackets)

Robust EU1 (0):

Default device parameter set with a static alarm threshold of 60 ppm CO. This parameter set has a large compensation range and rapid compensation. Warning level 3 is not output in the default device parameter set.

Balanced EU2 (1):

This parameter set corresponds to the dynamic CO alarm thresholds according to EN 50291. The parameter set has a small compensation range.

Static 40 (4):

This parameter set has a static alarm threshold of 40 ppm CO. The parameter set has a small compensation range.

Static 50 (5):

This parameter set has a static alarm threshold of 50 ppm CO. The parameter set has a small compensation range.

Static 60 (6):

This parameter set has a static alarm threshold of 60 ppm CO. The parameter set has a small compensation range.

Balanced US1 (7):

This parameter set corresponds to the dynamic CO alarm thresholds according to UL 2034. The parameter set has a small compensation range.

4.3.1.2 Use

No.	Name	Risk of increased concentration of CO (risk of damage to persons)	CO concentration	Room geometry	Deceptive phenomena	Compensation range
		small ... large	low ... high	simple ... complex	few ... many	small ... large
0	'Robust EU1'					
1	'Balanced EU2' ¹					
4	'Static 40'					
5	'Static 50'					
6	'Static 60'					
7	'Balanced US1' ¹					

¹ Time-dependent

4.3.1.3 Specification

The table below shows the characteristics and fields of application of the parameter sets for CO of the point detector.

No.	Name	Response thresholds of warning levels 1 to 3 'Technical CO Alarm' [ppm CO]				Alarming according to standard
		1	2	3		
				Static [ppm CO]	Concentration-dependent response time [min]	
0	'Robust EU1'	30	60	- ¹	-	-
1	'Balanced EU2'	30	50	-	≥ 120 @ 33 ±3 ppm CO 60...90 @ 55 ±5 ppm CO 10...40 @ 110 ±10 ppm CO ≤ 3 @ 330 ±30 ppm CO	EN 50291
4	'Static 40'	30	35	40	-	-
5	'Static 50'	30	40	50	-	-
6	'Static 60'	30	45	60	-	-
7	'Balanced US1'	30	50	-	60...240 @ 70 ±5 ppm CO 10...50 @ 150 ±5 ppm CO 4...15 @ 400 ±10 ppm CO	UL 2034

¹ Warning level 3 is not output in the default device parameter set.

Example for parameter set 1 'Balanced EU2' @ 55 ±5 ppm CO:

At 50 ppm CO, alarming must take place after between 60 and 90 minutes.



At an operating temperature of ≥80 °C, the CO sensor may not function reliably. Irreversible signaling of a critical fault therefore follows after four hours.



The point detector may only be used in continuous operation within the specified temperatures!

4.3.1.4 Default settings

When the point detector is supplied, the default device parameter set for CO (parameter set 0, 'Robust EU1') is set.

The optimum parameter set for CO must be selected when commissioning the fire detection system. The selection criteria are the existing risk and ambient conditions.

After the commissioning of the control panel, the fire detector is automatically set to its country-specific basic setting.

You can select and set the parameter sets with the 'Cerberus-Engineering-Tool' software.

You will find a description of the exact procedure for selecting and setting the parameters in the relevant documentation.



Please note the chapter 'Applicable documents'.

See also

Applicable documents [→ 9]

4.3.1.5 Application examples

The table below includes examples regarding the selection of the parameter set for CO for the point detector. The examples cannot be used universally, but illustrate typical applications.

Environment	Detection behavior wanted	Parameter set for CO
Rooms with open fire	Very fast response needed	'Static 40 (4)'
Heating rooms	Evaluation of time dependency of CO concentration	'Balanced EU2 (1)' or 'Balanced US1 (7)'
Combustion or fermentation plants	Very robust behavior towards deceptive phenomena	'Robust EU1 (0)'
Car parks, automotive workshops	Robust behavior towards deceptive phenomena	'Balanced EU2 (1)' or 'Balanced US1 (7)'
Underpasses and escape compartments	Evaluation of time dependency of CO concentration	'Balanced EU2 (1)' or 'Balanced US1 (7)'
Animal stalls	Fast reaction required	'Static 50 (5)'
Chemical labs or production sites	Fast and very sensitive reaction required	'Static 40 (4)' 'Alternatively Balanced EU2 (1)'

4.3.2 Ambient features

In selecting the optimum parameter set for CO, the following factors must be taken into account:

Positioning the point detector

CO is slightly less dense than air and spreads evenly through the room when at a constant temperature.

However if CO is produced in a fire, it is warmer than the surrounding air and rises towards the ceiling with the smoke. If the point detector is used as a fire detector for this situation, the same positioning rules apply to it as for a fire detector.

If the point detector is used for the 'Technical CO Alarm' and CO is produced from cold sources, the point detector must be installed in the ceiling too. Cold sources include e.g. gas cylinders in a laboratory. The positioning rules for gas detectors must be consulted for more details.

Influence of the surroundings

At temperatures in excess of +50 °C (outside the device specification!), the CO sensor ages faster than expected and the guaranteed 5-year service life for the point detector is reduced.

If the rooms requiring protection constantly have concentrations of ethanol of up to 500 ppm (= MAK value for ethanol), e.g., in breweries or whisky distilleries, since the electro-chemical cells have slight cross-sensitivity to ethanol, the 'Technical CO Alarm' is more likely to experience false alarms.

In a very dry and very hot climate, the response time of the CO sensor increases to around 120 s. The response of the point detector to relatively slow increases in the CO concentration, e.g. in the event of fires, is not therefore affected. But very quick increases in the CO concentration are detected with a slight delay.

The CO sensor responds faster in humid air than in dry air. There are no limits here on use as a fire detector or for the 'Technical CO Alarm'.

The electro-chemical CO sensor of the point detector has a slight cross-sensitivity to hydrogen (H₂), i.e., H₂ also causes CO signals. As H₂ can be produced when charging lead batteries and in electroplating plants, robust parameter sets which only cause an alarm when increased CO concentrations are detected should be used in such environments.

4.4 Technical Ambient Supervision Message



'Technical Ambient Supervision Message' mode can only be selected for point detector OOH740 from product version ES ≥ 20 .

The evaluation of the CO concentration in 'Technical Ambient Supervision Message' mode can only be selected for point detector OOHC740.



NOTICE

The system is not controlled as laid down in EN 54-2

Infringement of the EN 54-2 standard

- The signals for CO detection or temperature recording must not be used to control fire detection equipment in accordance with EN 54-2.

4.4.1 Ambient features

In markets where the use of the 'Technical Ambient Supervision Message' is permitted, the point detector can be positioned above or near objects which require the operating temperature or CO concentration to be monitored to prevent damage.

The following ambient conditions are detected in 'Technical Ambient Supervision Message' mode:

- An increase or decrease in temperature
- An increase in CO concentration

You can set the following parameters using the 'Cerberus-Engineering-Tool' software on the control panel:

- CO concentration or temperature threshold value
- Alarming when the temperature threshold value is exceeded or undershot
- Alarming when the CO concentration threshold value is exceeded
- Hysteresis range

You will find more detailed information in the fire detection system documentation.

Example of temperature monitoring caused by hysteresis:

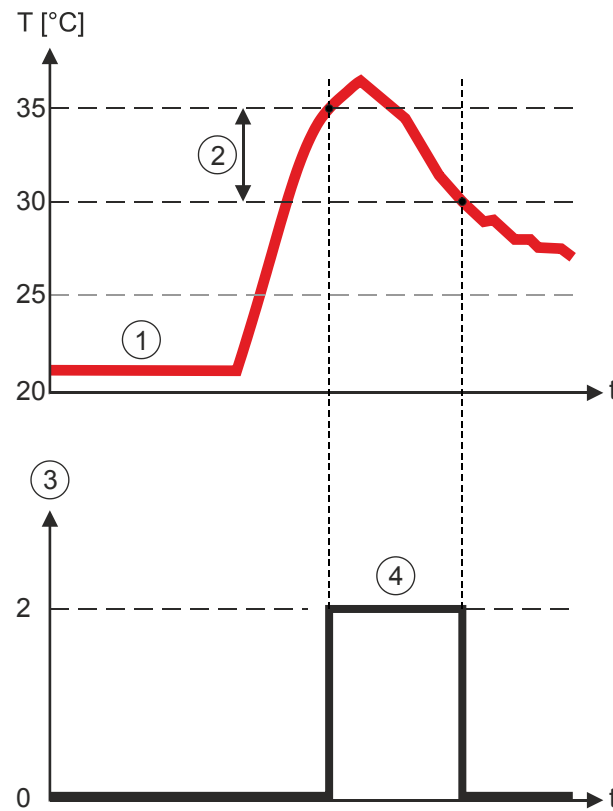

Figure 10: Ambient supervision output signal when the operating temperature threshold value of 35 °C is exceeded and a hysteresis range of 5 °C is selected. The diagram below shows the progression of the output signal.

- | | |
|---------------------------|-----------------------------|
| 1 Temperature progression | 3 Danger level ('0' or '2') |
| 2 Hysteresis range | 4 Output signal |

When an operating temperature of 35 °C is reached, the point detector sends a message with 'Danger level 2' to the control panel.

In the example shown, a further message with 'Danger level 0' is sent once the operating temperature of 30 °C (threshold value minus hysteresis range) is undershot.

4.4.1.1 Temperature monitoring

Temperature monitoring compares the current measured temperature with a preset threshold value.

You can select the following comparisons:

- **Temperature exceeded:** Alarming takes place when the measured temperature exceeds the set threshold value.
- **Temperature undershot:** Alarming takes place when the measured temperature undershoots the set threshold value.

The threshold value can be selected within a range that exceeds the permissible ambient temperature.

The adjustable threshold value for the OOHC740 is -20...+50 °C

The adjustable threshold for the OOH740 is -20...+55 °C.

Hysteresis ranges

You can set two hysteresis ranges:

- Normal hysteresis range with a range of 1 °C.
- Large hysteresis range with a range of 5 °C.

See also

 [Technical data for OOHC740 \[→ 100\]](#)

 [Technical data for OOH740 \[→ 103\]](#)

4.4.1.2 CO monitoring

CO monitoring compares the current measured CO concentration with a preset threshold value.

Alarming takes place when the current measured CO concentration temperature exceeds the set threshold value.

You can set the CO concentration threshold value in stages of 5 ppm between 20 and 600 ppm.

Hysteresis range and average over 15 minutes

You can choose between two options:

- A fixed hysteresis range of 5 % of the threshold value. Alarming takes place immediately if the threshold value is exceeded.
 - For low CO concentrations, a minimum hysteresis range of 2 ppm is specified.
 - For high CO concentrations, the hysteresis range is limited to 15 ppm.
- The average CO concentration over the last 15 minutes is calculated. Alarming takes place if the threshold value is exceeded. The hysteresis range is permanently set to 6 ppm.

4.4.2 Configuration

You can configure the point detector using the 'Cerberus-Engineering-Tool' software as follows:

Settings for temperature monitoring:

Adjustable values	Notes
Normal hysteresis range	Hysteresis range of 1 °C
Large hysteresis range	Hysteresis range of 5 °C
Temperature [°C]	Permissible threshold value range: -20...+50 °C for OOHC740 -20...+55 °C for OOH740
Temperature undershot/ temperature exceeded	Selects whether the output signal should be sent when the set threshold value is undershot or exceeded.

Settings for CO monitoring:

Adjustable values	Notes
Normal	Hysteresis range of 5 % of the threshold value, max. 15 ppm
Slow	Average CO concentration over 15 minutes, hysteresis range of 6 ppm
CO concentration in stages of 5 ppm	Permissible CO range: 20...600 ppm

4.4.3 Default settings

When the point detector is delivered, the 'Technical Ambient Supervision Message' mode is switched off.

You can switch on and configure the 'Technical Ambient Supervision Message' mode using the 'Cerberus-Engineering-Tool' software.

You will find more detailed information in the fire detection system documentation.

5 Mounting / Installation

5.1 Required space

- Upon insertion of the detector base and sounder base, the detector base is placed under stress by compression, tension, and torsion. The fastening method must, therefore, be designed accordingly.
- Detector bases and sounder bases must be placed flat on the ceiling.
- Avoid mounting on steps, concrete ribs, etc.
- Install the detector base or sounder base directly on the recessed box or a level surface.
- If a surface-mounted cable feed is used, there are two possible break-out points on the detector base or sounder base for the cable entry. Max. cable diameter: 8 mm.
- The point detector must have at least 2 cm of free space to the side. Only then can the point detector be removed from the detector exchanger DX791 and the adapter for detector exchanger FDUD491.
- Contorted detector bases or sounder bases will complicate or even impede the insertion of detectors.

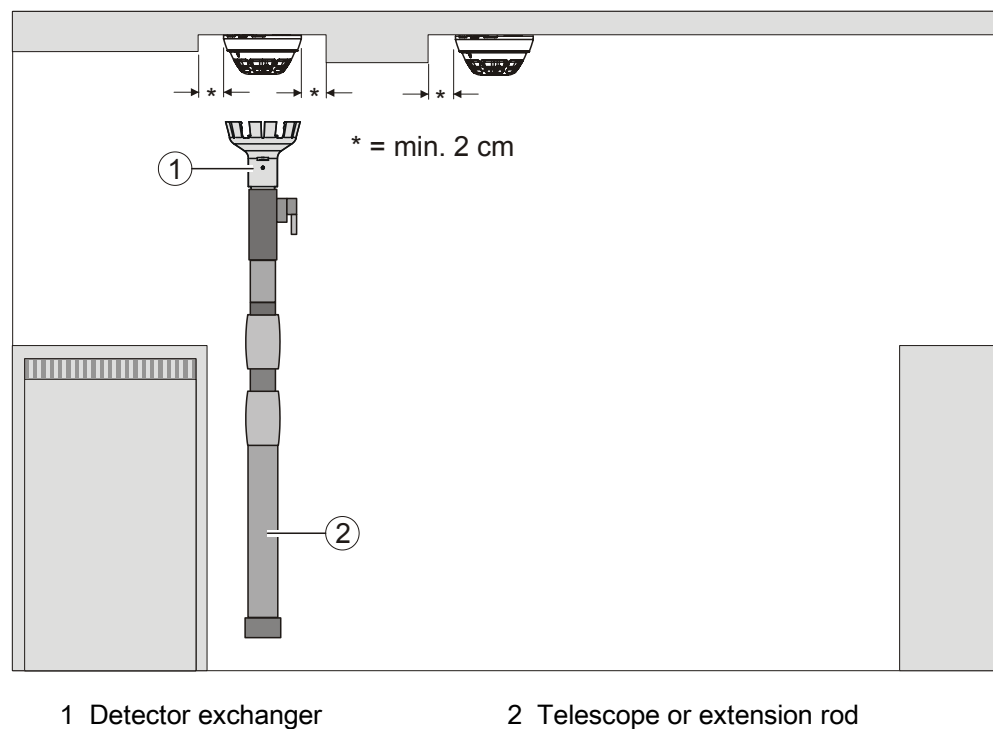

5.2 Detector base DB72x and detector base (collective) DB110

- Install the detector base DB72x or DB110 directly on the ceiling.
- Insert the cables into the detector base. You have the option of using the following types of line:
 - Recess-mounted cable entry
 - Surface-mounted cable entry (cable diameter max. 8 mm)

!	NOTICE
	<p>Incorrect laying of cables</p> <p>Damage to cables and difficulties when installing the point detector</p> <ul style="list-style-type: none"> • The cable loops must be placed flat in the base bottom. • The bare length of the cables is approximately 8...10 mm.

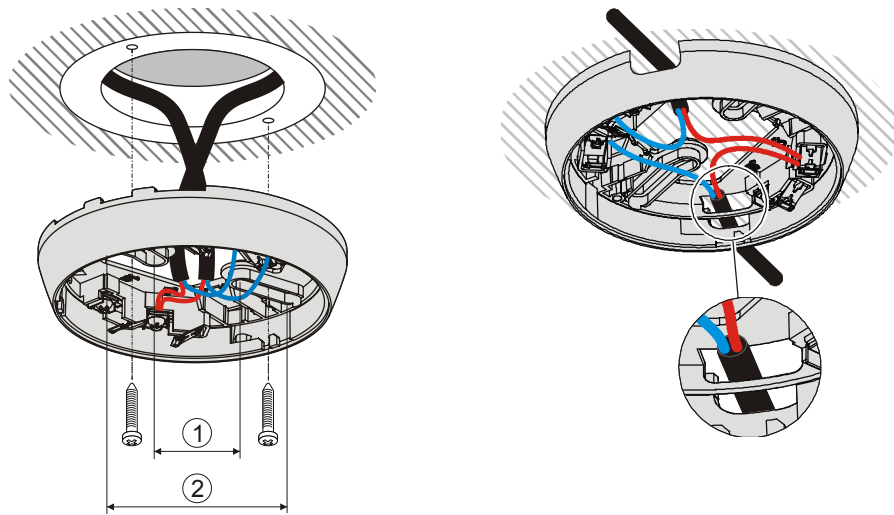

1 Minimum Ø 40 mm

2 Maximum Ø 90 mm



Please note the limitations when using the detector base DB721D. See chapter 'Connection diagram, collective [→ 88]'.



In the case of the detector bases DB721 and DB722, the C-NET detector line is not interrupted even if a point detector is not used.



Only use the detector base DB110 on collective detector lines.

Connection terminals

The following detector bases have screw terminals:

- DB721
- DB721D
- DB720
- DB110

The following detector bases have spring clips:

- DB722

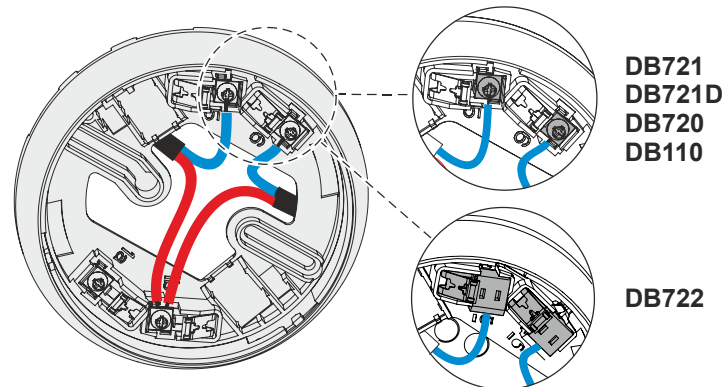

Figure 11: Screw terminals and spring clips

You will find information on connecting the detector bases in the chapters 'Cable entry [→ 85]' and 'Detector lines [→ 86]'.

5.3 Sounder base DBS720

1. Install the sounder base DBS720 directly on the ceiling.
2. Insert the cables into the sounder base DBS720. You have the option of using the following types of line:
 - Recess-mounted cable entry
 - Surface-mounted cable entry (cable diameter max. 8 mm)

!	<p>NOTICE</p> <p>Incorrect laying of cables</p> <p>Damage to cables and difficulties when installing the point detector</p> <ul style="list-style-type: none"> • The cable loops must be placed flat in the base bottom. • The bare length of the cables is approximately 8...10 mm.
----------	--

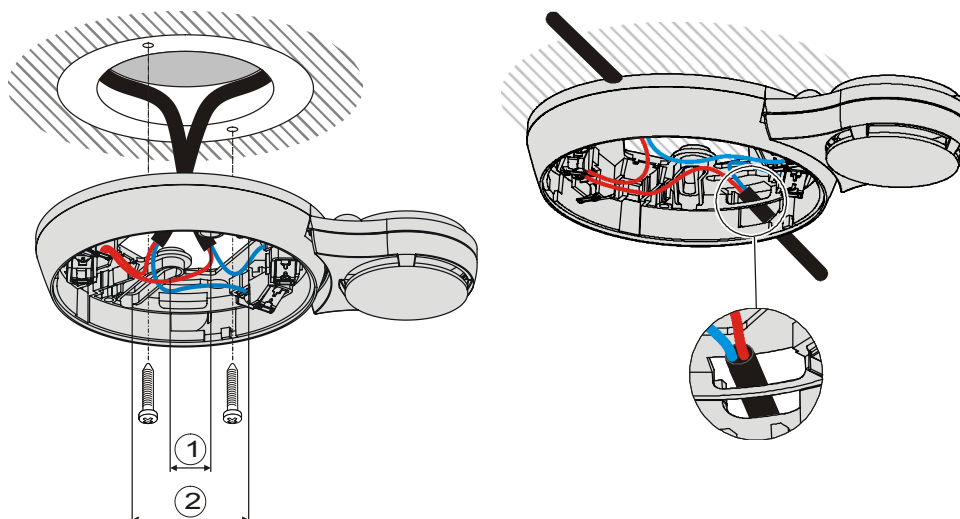

1 Minimum Ø 40 mm

2 Maximum Ø 90 mm



In the case of the sounder base DBS720, the C-NET detector line is not interrupted even if a point detector is not used.

5.4 Detector base seal RS720

- Use the detector base seal RS720 to install point detectors in wet rooms. Protection category: IP42.
- Compatible with the detector bases DB72x, the detector base (collective) DB110 and the sounder base DBS720.
- Only use for recess-mounted cable entry.

Installing the detector base seal

1. **NOTICE! Excessively large holes in the detector base seal will impair the potential IP protection category.** Do not cut or drill holes in the detector base seal. Without using a tool, push the lines through the detector base seal.
2. Fit the detector base seal RS720 between the ceiling and the detector base or the sounder base.

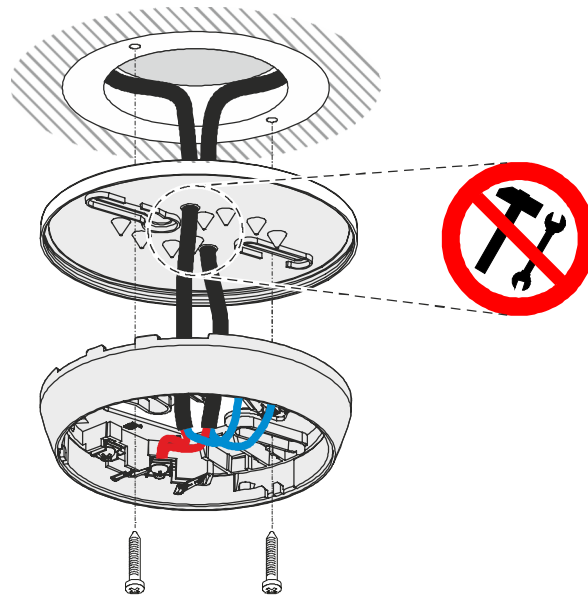

Figure 12: Installing the detector base seal RS720

5.5 Base attachment BA720

Install base attachment BA720 if you are using a cable with a diameter >8 mm for surface-mounted cable entry.

The base attachment BA720 is attached to the ceiling together with a detector base.

Compatible with the detector bases DB72x and DB110x.

Mounting for recess-mounted cable entry:

1. Insert the cables into the base attachment BA720 (1).
2. Install the base attachment BA720 (1) on the ceiling together with a detector base (2).
3. Connect the cables in the detector base (2).

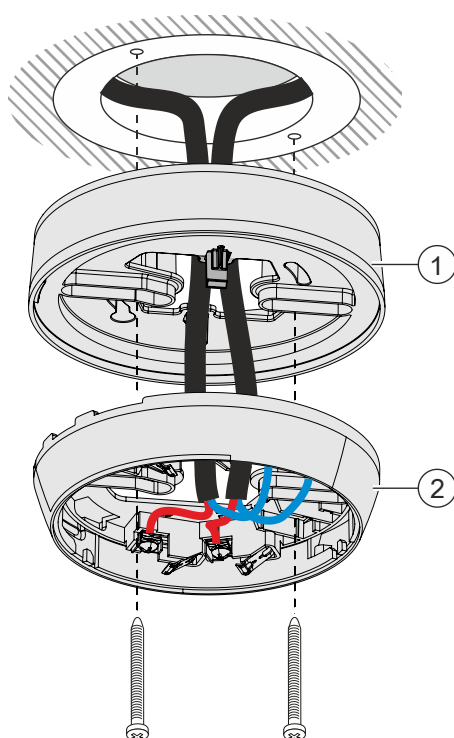

Figure 13: Recess-mounted cable entry with base attachment BA720

1 Base attachment BA720

2 Detector base DB72x

Mounting for surface-mounted cable entry:

1. Break out the areas required for cable entry in base attachment BA720 (1).
2. Insert the cables into the base attachment BA720 (1) through the broken-out areas.
3. Install the base attachment BA720 (1) on the ceiling together with a detector base (2).
4. Connect the cables in the detector base (2).

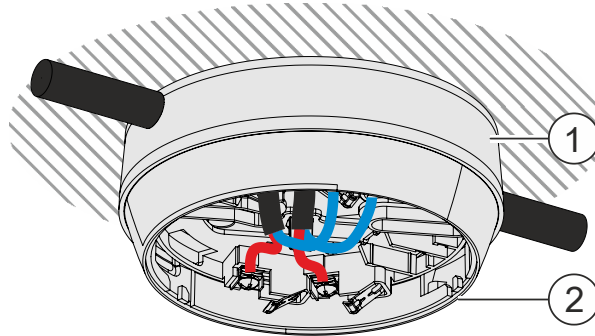

Figure 14: Surface-mounted cable entry with base attachment BA720

1 Base attachment BA720

2 Detector base DB72x

5.6 Base attachment wet BA721

Base attachment wet BA721 is for surface-mounted feed lines in humid and cold environments. The cables are inserted using M20 x 1.5 metal cable glands (Fig. 3). Protective cages DBZ1194/FDBZ294 can be installed on 'base attachment wet BA721'.

- Protective cage DBZ1194 (Fig. 3) protects the detector against mechanical damage.
- EMC-protective cage FDBZ294 (Fig. 4) protects the detector against mechanical damage and electromagnetic fields.



Note the dimensions of the protective cages (Fig. 3) before installing base attachment wet BA721!

You will find information on connecting detector heating unit FDBH291 in the 'Connection of the detector heating unit' chapter.

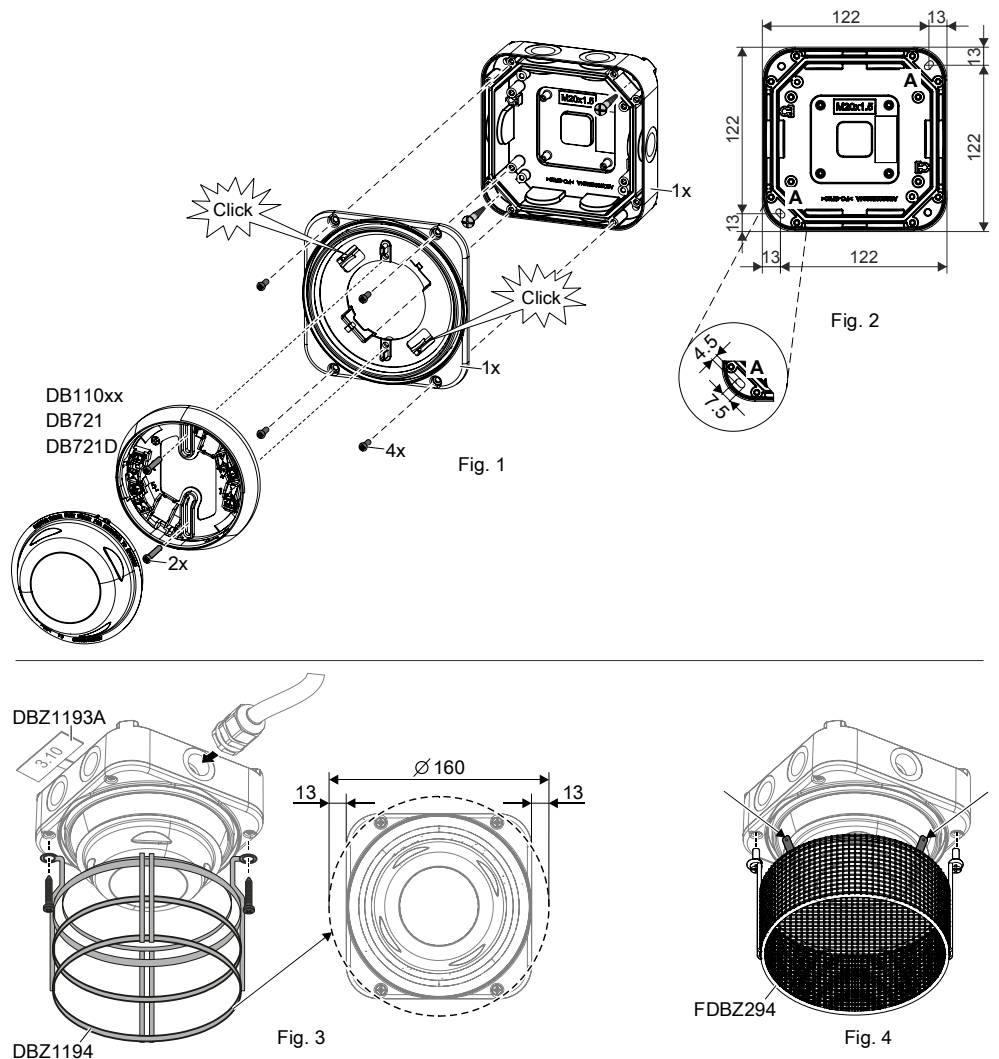

Figure 15: Installation and removal of protective cages and designation plates on base attachment wet BA721

Fig. 1 Installation of base attachment wet BA721

- Installation on back box on substructure (2 screws)
- Installation of housing cover on back box (4 screws)
- Installation of detector base (2 screws)

Fig. 2 Master gauge for recesses

Fig. 3 Installation of protective cage DBZ1194, M20 x 1.5 metal cable gland, designation plate DBZ1193A

Fig. 4 Installation of EMC-protective cage FDBZ294



⚠ WARNING

Danger of falling

Danger of injury

- When installing, use a secured ladder or work platform.
- Only use detector exchanger DX791 as an installation tool.

Installation (Fig. 1 and Fig. 2)

1. Install the M20 x 1.5 metal cable gland(s) in the back box of the base attachment wet.
2. Fit the back box securely to the substructure with 2 screws (detail A).
3. Screw the housing cover to the back box with the 4 screws.
4. Push the detector base into base attachment wet BA721.
⇒ You must be able to hear the detector base click into place.
5. Screw the detector base securely onto base attachment wet BA721 using 2 screws.

Removing the detector base

1. Loosen the two screws on the detector base.
2. Disengage the lock with a screwdriver ('click').
3. Remove the detector base from base attachment wet BA721.

See also

- 📄 [Protective cage DBZ1194 \[→ 52\]](#)
- 📄 [Detector heating unit FDBH291 \[→ 52\]](#)

5.7 Detector locking device LP720

A point detector can be protected against theft with the detector locking device LP720.

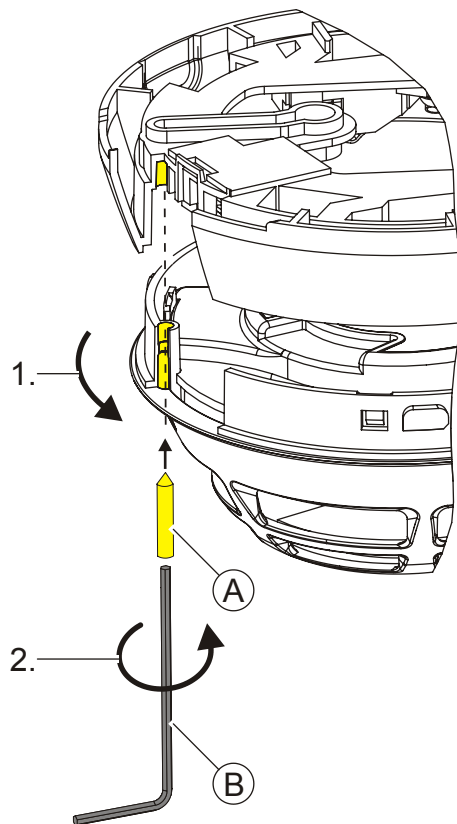

Figure 16: Installing the detector locking device LP720

A Set screw M3 x 12 mm

B Allen key

1. Insert the point detector into the detector base.
2. Using the Allen key provided, insert the set screw through the hole in the detector housing and tighten.

5.8 Designation plate FDBZ291

1. Label designation plate FDBZ291 with location address of point detector.
2. Attach designation plate FDBZ291 to detector base DB72x or detector base (collective) DB110.



If the detector base seal RS720 is being used, it is not possible to install the designation plate FDBZ291.

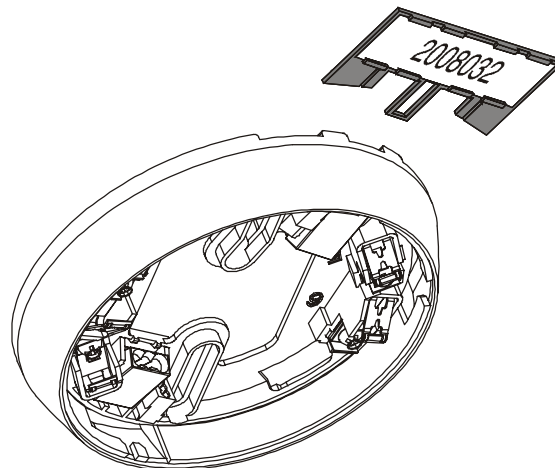
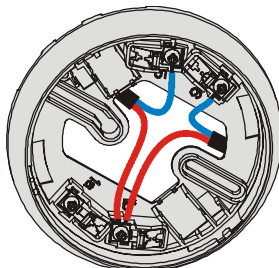

Figure 17: Mounting of designation plate FDBZ291

5.9 Cable entry

The detector bases DB72x and DB110 contain four screw terminals. A maximum of 2 cables may be connected to each screw terminal.

The cable cross section of the screw terminals is 0.2...1.6 mm².



Terminal assignment in addressed operation

Terminal name	Connection
1a	+Connection for external alarm indicator
1b	+C-NET IN and OUT
5	-C-NET IN or OUT / -external alarm indicator
6	-C-NET IN or OUT / -external alarm indicator

Terminal assignment in collective operation

Terminal name	Connection
1a	+Connection for external alarm indicator
1b	+Collective detector line IN and OUT
5	-Collective detector line IN (from the control panel) / -external alarm indicator
6	-Collective detector line OUT (from the EOL) / -external alarm indicator

The resistor for selecting the parameter set must be installed between terminals '5' and '1a'.

!	NOTICE
	<p>Incorrect laying of cables</p> <p>Damage to cables and difficulties when installing the point detector</p> <ul style="list-style-type: none"> • The cable loops must be placed flat in the base bottom. • The bare length of the cables is approximately 8...10 mm.

5.9.1 Auxiliary terminals DBZ1190-AA/-AB

Use the following auxiliary terminals for multiple connections:

- DBZ1190-AB connection terminal 1...2.5 mm²
- DBZ1190-AA micro terminal 0.28...0.5 mm²

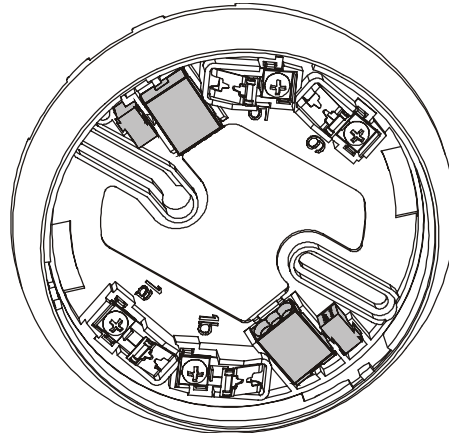

Figure 18: Detector base with connection terminals and micro terminals

5.10 Detector lines

5.10.1 Connection diagram, addressed

Cables and topology

- The connection is established from base to base using twisted or non-twisted wire pairs.
- Wherever possible use twisted, unshielded cables.
- Shielded cables are only required in special cases, such as strong high-frequency fields.
- You have the option of using the following types of line:
 - Loops
 - Stub lines
 - Stub line as a branch of a loop

Connecting external alarm indicators FDAI91 / FDAI92 / FDAI93

Observe the following points when connecting external alarm indicators:

- Wherever possible use twisted, unshielded cables.
- Connect a maximum of two external alarm indicators to one detector.
- If a cable with shielding is used to connect the external alarm indicator, this shielding must be linked to the shielding of the detector bus.
The shielding must not be linked to the external alarm indicator itself.

C-NET connection diagram

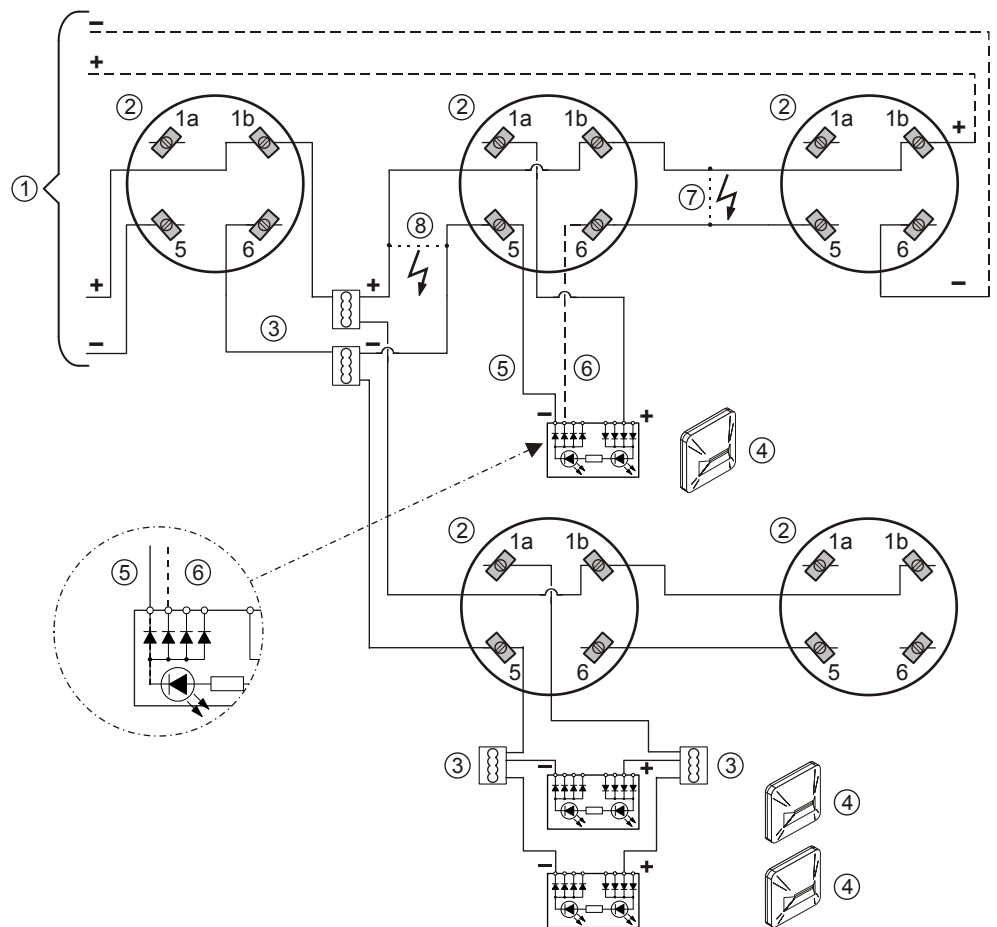

Figure 19: Connection diagram for addressed detector lines

- | | |
|--|--------------------------|
| 1 Control panel | 5 Cable -EAI6 |
| 2 Detector base DB72x, sounder base DBS720 | 6 Cable -EAI5 (optional) |
| 3 Auxiliary terminal DBZ1190-xx | 7 Short circuit (error) |
| 4 External alarm indicator | 8 Short circuit (error) |

The alarm indicator connected will continue to function correctly in the event of a short-circuit occurring at position '7' on the connection diagram. The alarm indicator is triggered by cable -EAI6.

If the short-circuit occurs at position '8' on the connection diagram, the alarm indicator will no longer be triggered.

As an option, the alarm indicator may also be connected using cable -EAI5. In this case, the alarm indicator will correctly indicate an alarm even if a short-circuit occurs at position '8'.

This ensures that the alarm indicator is always functioning correctly.



The option described is possible in loops and stub lines.

You will find more detailed information in the fire detection system documentation.

5.10.2 Connection diagram, collective

If the point detector OOH740 is used on a collective detector line, the parameter set is selected by installing a resistor PSR720-1 or PSR720-2 in the detector base. The resistors are available as accessories.

You can select parameter sets by installing or leaving out the following resistors:

Parameter set	Resistance value	Resistance
'Standard Plus'	-	-
'Suppression'	33 kΩ	PSR720-1
'High Sensitive Fast'	68 kΩ	PSR720-2

Proceed as follows to install the point detector OOH740 on a collective line:

1. Only install detector base DB721D or detector base (collective) DB110 on the detector line.
 2. If necessary: Install a resistor between terminals '1a' and '5'.
 3. Install one point detector OOH740 on each detector base.
- ⇒ Mounting of the point detector is complete.



Use of the detector base DB721D makes it easier to subsequently migrate the fire detection installation from a collective detector line to an addressed detector line. The detector bases no longer need to be replaced.

Limitations when using the detector base DB721D

Only install the detector base DB721D when the following conditions are satisfied:

- The control panel can detect that the point detector has been removed from the detector base with a diode.
- Downstream detectors on the stub are still operated correctly when the point detector is removed.

Control panels FC10 with a 'British Standard Module' satisfy these conditions.

You will find detailed information in the 'List of compatibility'.

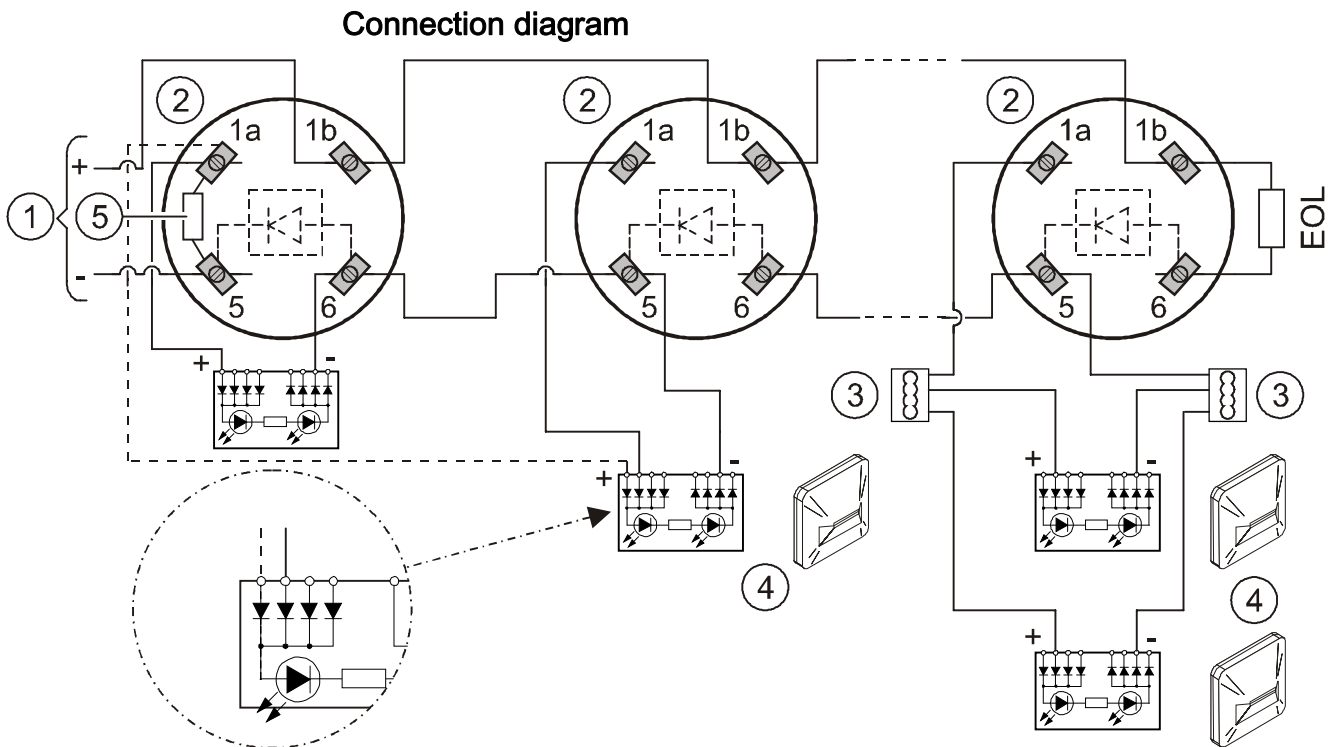

Figure 20: Connection diagram for collective detector lines

- | | |
|---------------------------------|---|
| 1 Control panel | 4 External alarm indicator |
| 2 Detector base DB721D or DB110 | 5 Resistor for selecting the point detector's parameter set |
| 3 Auxiliary terminal DBZ1190-xx | |

Connection for terminals '5' and '6'

If a point detector is removed from its detector base, all downstream detectors on the stub remain active.

This function is only guaranteed if the following points are observed when installing the detector base DB721D:

- The cable coming from the control panel or the control panel's cable is connected to terminal '5'.
- The cable routed towards the EOL resistor is connected to terminal '6'.



Check that the cables are installed correctly by performing an appropriate function test.

Diode unit for detector base DB721D

A missing, damaged or incorrectly installed diode unit can impair detection of a point detector being removed from its detector base. Check that the diode unit is functioning correctly by performing an appropriate function test.

See also

- ▣ Parameter sets for fire detection [→ 33]
- ▣ Parameter set resistor 33 kΩ PSR720-1 [→ 53]
- ▣ Parameter set resistance 68 kΩ PSR720-2 [→ 54]

5.11 Detector dust cap

1. Cover the point detector with the detector dust cap during the construction phase. This will protect the point detector from dust and dirt.
2. Once construction work is complete, remove the detector dust cap from the point detector.

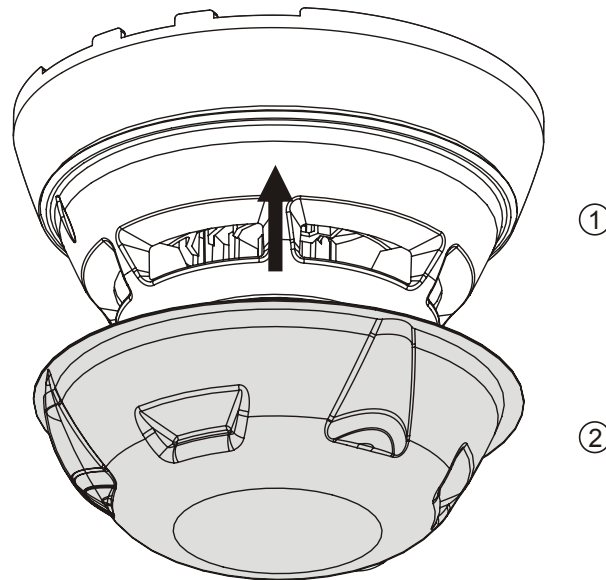

1 Point detector

2 Detector dust cap



A detector dust cap is provided as part of the scope of supply for each point detector.

5.12 Detector heating unit FDBH291

5.12.1 Installation of the detector heating unit

When the detector is exposed to icing or moisture condensation (e.g., in cooling rooms, attics, loading ramps), detector heating unit FDBH291 is installed in the detector base. The detector heating unit increases the detector temperature by approximately 2 °C over the ambient temperature and thus avoids moisture condensation on the detector.



Optimum function of the detector heating unit is only guaranteed with base attachment wet BA721.

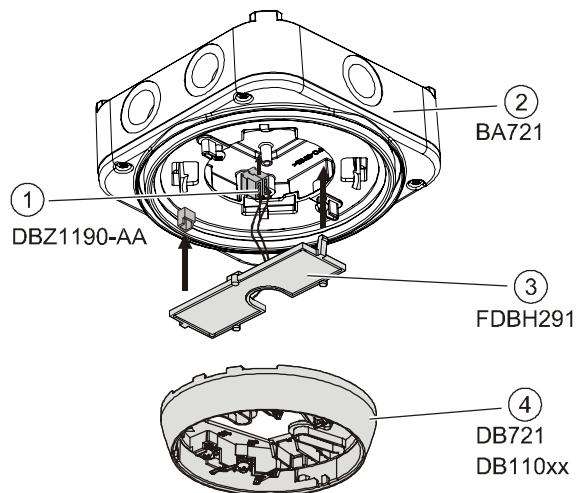

Figure 21: Mounting of the detector heating unit FDBH291

- | | |
|-----------------------|-------------------------|
| 1 Micro terminals | 3 Detector heating unit |
| 2 Base attachment wet | 4 Detector base |

5.12.2 Connection of the detector heating unit

- Connect the cables for the monitored supply from the control panel and the detector heating unit to the supplied micro terminals DBZ1190-AA.
- The cables can be placed in the same cable harness as the detector line or separately.
- Several detector heating units can be connected in parallel.
- Detector heating units require a separate supply.



NOTICE

Risk of icing

Malfunction

- To ensure smooth operation, the detector must be checked regularly for icing.

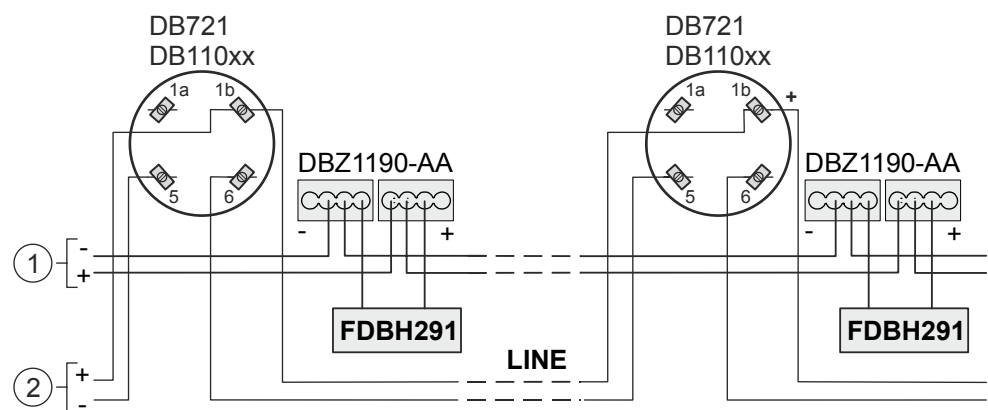

Figure 22: Connection diagram for detector heating unit FDBH291

1 Control panel supply (monitored)

2 Control panel

5.13 Migration from collective detector line to addressed detector line

- ▷ One fire detection installation is installed for collective detector lines.
- ▷ Detector bases DB721D are installed on the detector line.
- ▷ Point detectors OOH740 are installed in the detector bases DB721D.
- 1. Install a fire detection installation with one C-NET detector line
- 2. Remove the point detector from the detector base.
- 3. Remove the diode unit from the detector base DB721D. See the chapter 'Removing the diode unit [→ 94]'.
- 4. If a resistor for selecting a parameter set in collective mode is installed in the detector base DB721D: Remove the resistor.



Because the resistor is no longer needed, e.g. the connection wires of the resistor can be cut using a wire cutter or another cutting tool.

- 5. Install the point detector on the detector base.
- 6. Repeat steps 1 to 5 for each detector base.
 - ⇒ The fire detection installation detects the point detectors on the addressed detector line during commissioning.
- 7. During commissioning, check the set parameter set on each point detector. If necessary, select another parameter set.
 - ⇒ Migration is complete.



If there are a lot of collective point detectors on one stub, it is often the case that not all of the detectors are detected when the detector line is first started up. In this instance, restart the detector line. Repeat this process until all of the detectors are detected by the control panel.

See also

- Connection diagram, collective [→ 88]
- Removing the diode unit [→ 94]

5.13.1 Removing the diode unit

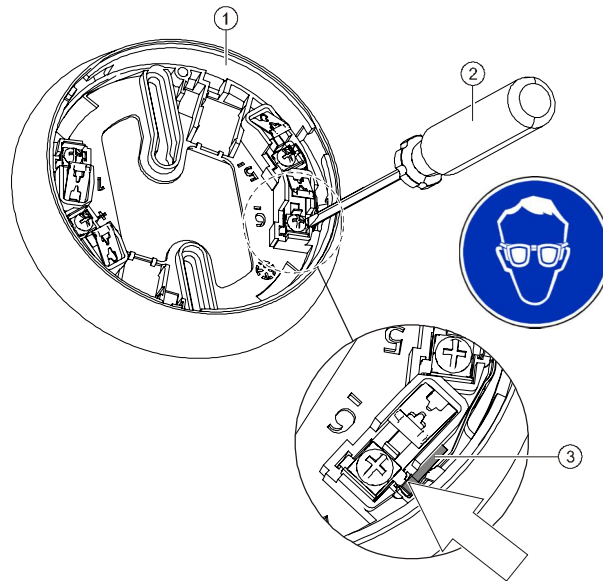

Figure 23: Removing the diode unit

1 Detector base DB721D

3 Diode unit

2 Screwdriver size 1



⚠ WARNING

Falling diode unit

Risk of eye damage

- Wear safety goggles when removing the diode unit!

▷ There is no point detector in the detector base DB721D.

1. Attach a size 1 screwdriver (2) between the connection terminal '6' in the detector base (1) and the diode unit (3). See arrow in the figure.
2. **NOTICE! The loop contact in the detector base is damaged when the diode unit is removed! Avoid bending the spring contact next to the connection terminal '6'!**
3. Hit the handle of the screwdriver (2).
⇒ The diode unit (3) falls out of the detector base (1).

6 Commissioning

6.1 Commissioning on the C-NET

The devices are commissioned via the control panel. The exact procedure is described in the control panel documentation.

Conduct a performance check once commissioning is complete.

6.2 Commissioning on a collective detector line

The devices are commissioned via the control panel. The exact procedure is described in the control panel documentation.

Conduct a performance check once commissioning is complete.

7 Maintenance / Repair

7.1 Performance check

The selftest automatically subjects the detectors to an extensive electrical performance check. Regular performance checks of the detectors are required nonetheless. This may be done with the test gas or hot air fan depending on the detector type.

Recommendation:

- Check the devices every year.
- Replace heavily soiled or damaged devices.
- All point detectors should be replaced after 6 to 8 years of service, depending on the ambient conditions.
- The CO sensor used in the OOHC740 has a maximum service life of 5 years. When CO-supported parameter sets are activated, a critical warning is triggered once this period has lapsed.

It can continue to be used as an OOHC fire detector depending on the fire control panel following reconfiguration to non-CO-supported parameter sets until the recommended replacement interval of 6 to 8 years is reached.

7.2 Testing the point detector

Depending on the point detector, testing may be performed with one or more of the following accessories:

- Test gas, optical
 - REF8-S (recommended)
 - REF8
- CO test gas
 - REF8-C (for CO sensors)
- Heat detector tester kit RE7T
- Hot air fan

Collective operation

In collective operation, the point detector OOHC740 has a reduced response time for a period of 3 minutes following the detector line being started up or reset. In this time, the point detector responds faster to test gas or a hot air fan than in normal operation.

Once an alarm is triggered on a point detector, the detector line must be restarted. Only then can the next point detector be tested.

You will find more detailed information in the fire detection system documentation.

See also

- 📄 Test mode on the control panel [→ 97]

7.2.1 Test mode on the control panel

The fire detectors are highly resistant to deceptive phenomena. This means that optical fire detectors, for example, will recognize the immediate occurrence of smoke (such as that which occurs during testing with test gas) as a deceptive phenomenon and will not trigger an alarm. This is desirable in normal operation; however, it does make testing with test gas problematical.

To enable detector testing with test gas or with a hot air fan, the detector must be switched to test mode.

On an addressed detector line, the point detector or detector zones can be switched to 'Test' on the control panel. Testing with test gas is then possible without problems.

Collective operation



Collective control panels can be switched to test mode too. In this instance, however, only the output of a real alarm is prevented. With collective control panels, test mode has no influence over point detectors' response times.

The detector must be disconnected from the power supply on a collective detector line such that it switches to test mode.

You can do the following to disconnect the power supply:

- Restart the detector line
- Remove from the detector base for at least 5 s the detector to be tested first in a detector line and then reinsert it

The point detectors then have a reduced response time for 3 minutes.



To trigger a detector using test gas, normally 2...4 gas discharges at intervals of approx. 2 seconds are required. When the detector is working in test mode, activation takes place after approximately 10 seconds.

See also

 Testing the point detector [→ 96]

7.2.2 Testing the fire detection functionality

The table below shows the accessories with which the fire channel can be tested in the various sensor modes.

Fire detector FDOOTC241	Test gas		Hot air fan
	Optical	CO	
Sensor mode 0 (neural fire detector)	X	X	X
Sensor mode 1 (heat detector)	–	–	X
Sensor mode 2 (smoke detector)	X	–	–

If the point detector is working in test mode, the following must be noted:

In test mode, the point detector responds according to the sensor mode selected. This means when the point detector is operated as a heat detector (sensor mode 1), it must be thermally checked as well.



Selecting test mode for the fire zone on the fire control panel does not deactivate evaluation of the functionality of the 'CO Technical Alarm' and 'Ambient Supervision Technical Alarm'.



When the detector is in alarm condition, the internal alarm indicator flashes. For information on the flashing modes, observe the notices in chapters 'Internal alarm indicator in the case of ES <20 (OOH740 and OOHC740) [→ 40]' and 'Advanced flashing behavior of the alarm indicators in the case of ES ≥20 (OOH740 and OOHC740) [→ 41]'.

7.2.3 Testing the CO functionality (only for OOHC740)

The table below shows the accessories with which the gas channel can be tested.

Gas channel	Test gas		Hot air fan
	Optical	CO	
Technical CO alarm	–	X	–

If the point detector OOHC740 is working in test mode, the following must be noted:

Because the fire detection functionality is not automatically deactivated during test mode for CO, the documentation provided for the control panel must be consulted for details of how to proceed.



If using CO test gases which haven't been approved, a fire alarm may be triggered during testing if additional setting of test mode is not undertaken on the fire control panel.

7.2.4 Testing the functionality of the 'Technical Ambient Supervision Message'

You do not have to check the functionality of the 'Technical Ambient Supervision Message' on a regular basis.

Testing the fire detection functionality and the CO functionality ensures that the 'Technical Ambient Supervision Message' is also working.

7.2.4.1 'Technical Ambient Supervision Message' performance check

You cannot test whether the 'Technical Ambient Supervision Message' is functioning correctly with test devices.

Checking can only take place indirectly:

- ▷ You must know the current ambient temperature.
- Enter the following parameters in the 'Cerberus-Engineering-Tool' software:
 - A hysteresis range of 5 °C.
 - A temperature threshold which is at least 10 °C below the current ambient temperature.
 - Alarming when value falls below threshold
- ⇒ The detector sends a signal to the control panel.
- ⇒ The 'Technical Ambient Supervision Message' is working correctly if the control panel displays the corresponding message.

8 Specifications

Unless otherwise mentioned, the following data applies:

Temperature	= 25 °C
Air pressure	= 1000 hPa (750 Torr)

8.1 Technical data for OOH740

You will find information on approvals, CE marking, and the relevant EU directives for this device (these devices) in the following document(s); see 'Applicable documents' chapter:

- Document A6V10284161

Addressed detector line (C-NET)

Detector line	Operating voltage (modulated)	DC 12...33 V
	Operating current (quiescent)	Typ. 170...250 µA
	Maximum current connection factor	1
	Quiescent current connection factor	1
	Address connection factor	1
	Separator connector factor	1
	Protocol	C-NET or collective (automatic detection)
	Compatibility	See 'List of compatibility'
Line separator	Line voltage:	
	• Nominal	DC 32 V (= V_{nom})
	• Minimum	DC 12 V (= V_{min})
	• Maximum	DC 33 V (= V_{max})
	Voltage at which the line separator opens:	
	• Minimum	DC 7.5 V (= $V_{SO min}$)
	• Maximum	DC 10.5 V (= $V_{SO max}$)
	Permanent current when switches are closed	Max. 1.5 A (= $I_{C max}$)
	Switching current (e.g., in the event of a short-circuit)	Max. 2 A (= $I_{S max}$)
	Leakage current when switches are open	Max. 1 mA (= $I_{L max}$)
Serial impedance when switches are closed	Max. 0.4 Ω (= $Z_{C max}$)	

When operated on the C-NET, the line separator is closed via an actuation signal from the control panel. Required line voltage: DC 12...33 V (normal range)

External alarm indicator	External alarm indicators which can be connected	2 external alarm indicators and 1 sounder base	
	Voltage	DC 10...17 V	
	Current	9...15 mA	
	Flashing interval times:		
	<ul style="list-style-type: none"> • Normal bright flashing • Faint flashing 	15 ms 1 s	
Device characteristics	Response sensitivity (typ.)	1.5...12 %/m (depending on the parameter set) Note: The limit for the 'Ultra Sensitive' parameter set is 0.5 %/m. However, this parameter set does not meet the requirements of EN 54-7.	
	<ul style="list-style-type: none"> • Permissible wind speed • Compensation speed 	Max. 5 m/s ≤ 1/45 voltage increase for detection/h	
Ambient conditions	Operating temperature	-25...+55 °C	
	Storage temperature	-30...+70 °C	
	Optimum storage temperature	0...+20 °C	
	Air humidity	≤95 % rel.	
	Protection category (IEC 60529):		
	<ul style="list-style-type: none"> • Detector base DB721/DB721D/DB110 • Detector base DB721/DB721D/DB110 and sounder base DBS720 with detector base seal RS720 • Sounder base DBS720 • Base attachment wet BA721 	IP40 IP44 IP40 IP44	
	Electromagnetic compatibility:		
	<ul style="list-style-type: none"> • 10 kHz...2.7 GHz 	50 V/m	
	Mechanical data	Dimensions (Ø x H) with detector base:	117 x 49 mm
		Color	~RAL 9010 pure white
Standards	European standards	<ul style="list-style-type: none"> • EN 54-5 • EN 54-7 • EN 54-17 • CEA 4021 	

Collective detector line

Detector line	Operating voltage	DC 14...28 V
	Maximum current connection factor	See 'Collective maximum current connection factor' table
	Quiescent current at:	
	• Maximum current connection factor = 1	65...100 µA
	• Maximum current connection factor = 1.25	80...125 µA
	Current peak at:	
	• Maximum current connection factor = 1	150 µA
	• Maximum current connection factor = 1.25	180 µA
	Alarm voltage at:	
	• Alarm current = 1...15 mA	DC 5...10 V
	• Alarm current = 35 mA	DC 18...22 V
	• Alarm current = 50 mA	DC 26...28 V
	Alarm current at operating voltage = DC 5...28 V	4...50 mA
Reset voltage UR:		
• Alarm is reliably reset	DC 0...2 V	
• Alarm may possibly not be reset	DC 2...4 V	
Reset time at UR ≤ DC 2 V:		
• Alarm is reliably reset	>2 s	
• Alarm may possibly not be reset	1...2 s	
Protocol	Collective (with and without current limitation)	
Compatibility	See 'List of compatibility'	

Collective maximum current connection factor

Parameter set	Maximum current connection factor	Resistance value in the detector base
'Standard Plus'	1	-
'Suppression'	1.25	33 kΩ
'High Sensitive Fast'	1.25	68 kΩ

8.2 Technical data for OOH740

You will find information on approvals, CE marking, and the relevant EU directives for this device (these devices) in the following document(s); see 'Applicable documents' chapter:

- Document A6V10284161

Detector line	Operating voltage (modulated)	DC 12...33 V
	Operating current (quiescent)	Typ. 300...380 μ A
	Maximum current connection factor	2
	Quiescent current connection factor	2
	Address connection factor	1
	Separator connector factor	1
	Protocol	C-NET
	Compatibility	See 'List of compatibility'
Line separator	Line voltage:	
	• Nominal	DC 32 V (= V_{nom})
	• Minimum	DC 12 V (= V_{min})
	• Maximum	DC 33 V (= V_{max})
	Voltage at which the line separator opens:	
	• Minimum	DC 7.5 V (= $V_{SO min}$)
	• Maximum	DC 10.5 V (= $V_{SO max}$)
	Permanent current when switches are closed	Max. 1.5 A (= $I_{C max}$)
	Switching current (e.g., in the event of a short-circuit)	Max. 2.0 A (= $I_{S max}$)
	Leakage current when switches are open	Max. 1 mA (= $I_{L max}$)
	Serial impedance when switches are closed	Max. 0.4 Ω (= $Z_{C max}$)
	Closing the line separators:	
	When operated on the C-NET, the line separator is closed via an actuation signal from the control panel. Required line voltage: DC 12...33 V (normal range)	
External alarm indicator	External alarm indicators which can be connected	2 external alarm indicators and 1 sounder base
	Voltage	DC 10...17 V
	Current	9...15 mA
	Flashing interval times:	
	• Normal bright flashing	15 ms
• Faint flashing	1 s	
Device characteristics	Response sensitivity (typ.)	3...12 %/m (depending on the parameter set)
	• Permissible wind speed	Max. 5 m/s
	• Compensation speed	$\leq 1/45$ voltage increase for detection/h
	CO sensor service life	Max. 5 years

Ambient conditions	Operating temperature	-20...+50 °C
	Storage temperature	-20...+55 °C
	Optimum storage temperature	0...+20 °C
	Air humidity	~15...95 % rel. during continuous operation
		Condensation water may impair the function of the CO sensor.
	Protection category (IEC 60529):	
	• Detector base DB721/DB721D/DB110	IP40
	• Detector base DB721/DB721D/DB110 and sounder base DBS720 with detector base seal RS720	IP44
	• Sounder base DBS720	IP40
	• Base attachment wet BA721	IP44
Mechanical data	Electromagnetic compatibility:	
	• 10 kHz...2.7 GHz	40 V/m
	Dimensions (Ø x H) with detector base:	117 x 49 mm
	Color	~RAL 9010 pure white
Standards	European standards	<ul style="list-style-type: none"> • EN 54-5 • EN 54-7 • EN 54-17 • CEA 4021

8.3 Dimensions

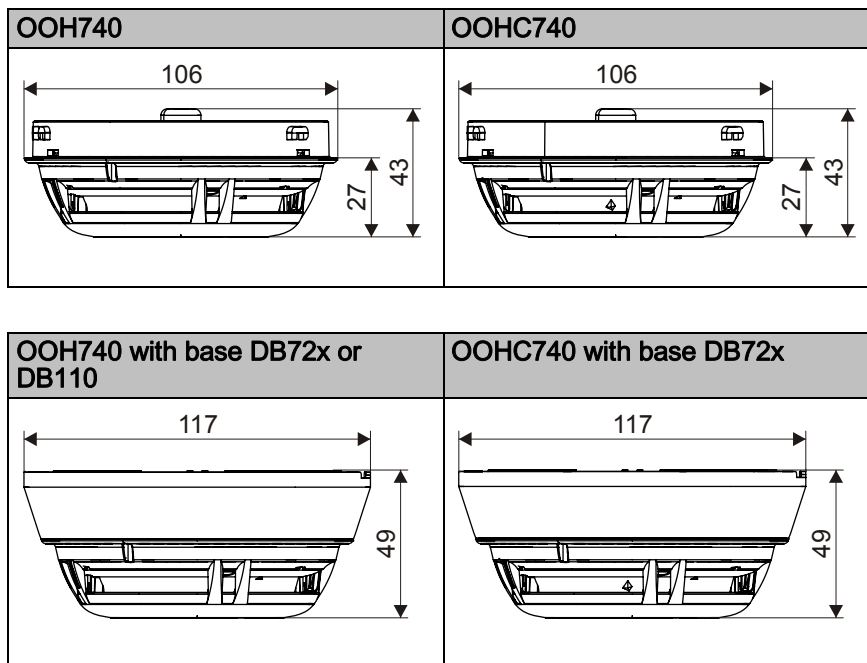

8.4 Environmental compatibility



This equipment is manufactured using materials and procedures which comply with current environmental protection standards as best as possible. More specifically, the following measures have been undertaken:

- Use of reusable materials
- Use of halogen-free plastics
- Electronic parts and synthetic materials can be separated

Larger plastic parts are labeled according to ISO 11469 and ISO 1043. The plastics can be separated and recycled on this basis.



Electronic parts and batteries must not be disposed of with domestic waste.

- Take electronic parts and batteries to local collection points or recycling centers.
- Contact local authorities for more information.
- Observe national requirements for disposing of electronic parts and batteries.

Index

- A**
- Ambient supervision** 21
 - Application as heat detector**
 - Sensor mode 1 31
 - Application as neural fire detector**
 - Sensor mode 0 31
 - Application as smoke detector**
 - Sensor mode 2 31
 - Approvals** 100, 103
 - ASAt echnology** 22
 - Auxiliary terminals**
 - Connection terminal 86
 - Micro terminal 86
- C**
- Cables** 86
 - Carbon monoxide**
 - CO 21
 - CE marking** 100, 103
 - CO**
 - Carbon monoxide 21
 - CO concentration** 31, 72
 - Average 72
 - Average over 15 minutes 72
 - CO sensor**
 - Detection of carbon monoxide 29
 - Collective behavior**
 - Degraded mode operation 45
 - Collective mode**
 - Internal alarm indicator 40
 - Product version and flashing modes 40
 - Setting for parameter sets 32
 - Compatibility** 55, 88
 - Compatibility with control panels** 55
 - Connection diagram** 86
 - External alarm indicators 86
 - Connection terminal** 86
 - Control panel** 95, 95
- D**
- Danger level**
 - Signal processing of the point detector 37
 - Default device parameter set** 33, 63, 68
 - Default parameter set 0**
 - Delivery 63
 - Degraded mode operation**
 - Collective behavior 45
 - Fire control panel failure 45
 - Delivery**
 - Default device parameter set 0 with sensor mode 0 63
 - Designation plate**
 - Detector base 84
 - Mounting 84
 - Sounder base 84
 - Detection behavior of the detector**
 - Parameter set 33, 36
 - Detection behavior of the point detector**
 - Parameter set 32
 - Detection of carbon monoxide**
 - CO sensor 29
 - Detector**
 - Performance check 96
 - Detector base** 46
 - Detector base (collective)** 46
 - Detector base seal**
 - Mounting 78
 - Detector dust cap** 90
 - Detector exchanger DX791** 46, 74
 - Adapter for detector exchanger FDUD491 46, 74
 - Detector heating unit**
 - Mounting 91
 - Detector line**
 - Connection diagram 86
 - Detector locking device**
 - Mounting 83
 - Diagnosis levels** 39
 - Fault 39
 - Normal 39
 - Observe information 39
 - Replacement necessary 39
 - Replacement recommended 39
 - Diode unit** 49
 - Correct function 89
 - Remove 89
 - Uninstalling 93
 - Disposal** 106
 - Documentation for fire detection system** 9, 32, 42, 63, 68
 - Download center**
 - URL 10

E	
Environmental compatibility	106
ES	
Product version	27
EU directives	100, 103
External alarm indicator	41, 43
Addressed mode	41
Alarm	41
Alarm in test mode	41
Can be operated in collective mode	43
C-NET	43
Collective mode	41
Sounder base	43
F	
Fire control panel failure	
Degraded mode operation	45
Flashing behavior	
Steady-on	42
Flashing mode	
Internal alarm indicator	41
Flashing pattern	
Configuration	41
Internal alarm indicator	41
H	
Hot air fan	
Test device	44
Hysteresis	29, 31
Hysteresis range	31, 70, 72
I	
Intended use	7
Internal alarm indicator	40
Alarm	40
Collective mode	40
Test mode	40
L	
Line separator	
Function	39
List of compatibility	9, 21, 45, 55, 88, 100, 103
Loop	86
M	
Maintenance intervals	96
Major renovation work	
Renovation mode	43
Micro terminal	86
O	
Order number	26
Original language	8
P	
Packaging label	
Product version	27
Parameter set	
Detection behavior of the detector	33, 36
Detection behavior of the point detector	32
Performance check	96
Product label	
Product version	27
PSR720-1	53
Resistance	88
PSR720-2	54
Resistance	88
R	
Recycling	106
Renovation mode	
Major renovation work	43
Required space	74
Resistance	
PSR720-1	53, 88
PSR720-2	54, 88
S	
Screw terminals	
Assignment	85
Sensor mode 0	
Application as neural fire detector	31
Sensor mode 1	
Application as heat detector	31
Sensor mode 2	
Application as smoke detector	31
Short-circuit	
Line separator	39
Reset the detector line	39
Signal processing of the point detector	
Danger level	37
Warning level	38
Sounder base	43, 46
Source language	8
Standards	101, 104
Steady-on	
Internal alarm indicator	42
Stub line	86



T	
Temperature exceeded	72
Temperature increase	29, 31
Temperature undershot.....	72
Test device	
Detector tester RE6T	44
Heat detector tester kit RE7T Solo461	44
Hot air fan.....	44
Test gases REF8, REF8-S.....	44
Test gases REF8, REF8-S	
Test device	44
Test mode	
Addressable detector	97
Collective detector	97
Threshold value	72, 72
Topology	86
Type plate	
Product version.....	27
W	
Warning level	
Signal processing of the point detector.....	38

Issued by
Siemens Switzerland Ltd
Building Technologies Division
International Headquarters
Gubelstrasse 22
CH-6301 Zug
+41 41-724 24 24
www.siemens.com/buildingtechnologies

© Siemens Switzerland Ltd, 2010
Technical specifications and availability subject to change without notice.